

DNP

Wireless Passport System

IDW500

version 3.1

User Guide

License Agreements

SOFTWARE END USER LICENSE AGREEMENT (EULA). PLEASE READ THE FOLLOWING TERMS AND CONDITIONS CAREFULLY BEFORE USING THIS SOFTWARE. USING THIS SOFTWARE INDICATES YOUR ACCEPTANCE OF THESE TERMS AND CONDITIONS. IF YOU DO NOT AGREE WITH THESE TERMS AND CONDITIONS, DO NOT DOWNLOAD OR USE THIS SOFTWARE. This Software License Agreement (the "Software License Agreement") is an agreement entered into by and between you (hereinafter referred to as "You" or "Your") and DNP Imagingcomm America Corporation (DNP IAM) (the "Licensor") for any and all software and documentation provided by the Licensor (the "Software"). The Software includes items available either by Internet download, contained in a CD/DVD or contained within a 3rd party software installer. By using the Software, You agree to the terms of this Software License Agreement. The Licensor grants You a non-exclusive, non-transferable license to use one copy of the Software in object code only.

OWNERSHIP RETAINED BY LICENSOR. The Licensor owns all title and copyrights in and to the Software and the Licensor has the full right and authority to grant the license granted herein. Your license does not give You any title or ownership in the Software, nor is it a sale of any rights in the Software. The only right granted to You is the right to use the Software in accordance with the terms of this Software License Agreement. All rights not specifically granted to You under this Software License Agreement are reserved by the Licensor. You may make only a single copy of the Software as a backup copy, provided that it includes all notices and markings, including copyright, trademark and other proprietary notices as on the original. Such backup copy of the Software may not be in use at any time unless the original Software is damaged beyond use, and both the original and the copy must remain in Your possession and control. You may not copy the software onto any public network. You may not, and You may not allow others to modify, disassemble, decompile, translate, reverse engineer, reproduce, make derivative works of or enhance the Software. You may not, and You may not allow others to rent, lease, sell, sub license, export or otherwise transfer the Software to any other person. In addition to any other rights it may have, the Licensor may terminate this Software License Agreement if You fail to comply with the terms and conditions hereof. In such event, You must cease all use of the Software and destroy all copies of the Software and all of its component parts. At the Licensor's sole discretion, the Licensor may from time to time provide You with updates to the Software. Any such updates shall become part of the Software licensed to You hereunder and subject to all of the terms and conditions of this Software License Agreement.

DISCLAIMER OF WARRANTIES. The Licensor expressly disclaims any and all warranties relative to the Software. THE SOFTWARE IS PROVIDED "AS IS," WITHOUT WARRANTY OF ANY KIND, EXPRESS OR IMPLIED, INCLUDING, WITHOUT LIMITATION, THE IMPLIED WARRANTIES OF MERCHANTABILITY AND FITNESS FOR A PARTICULAR PURPOSE, NON-INFRINGEMENT, COURSE OF DEALING AND USAGE OF TRADE. YOU HEREBY ASSUME THE ENTIRE RISK AS TO THE QUALITY AND PERFORMANCE OF THE SOFTWARE.

LIMITATION OF LIABILITY. In no event shall the Licensor be liable for any direct, special, incidental, indirect or consequential damages whatsoever to You (including, without limitation, damages for loss of profits, sales or data or for business interruption) arising out of the use of or inability to use the Software, even if the Licensor has been advised of the possibility of such damages. In any event, the Licensor's entire liability under any provision shall be limited to the amount actually paid by You for the Software. Because some states and jurisdictions do not allow the exclusion or limitation of liability, the above limitation may not apply to You. If any provision of the Software License Agreement is declared by a court of competent jurisdiction to be invalid for any reason, such invalidity shall not affect the remaining provisions hereof.

GOVERNING LAW. This Software License Agreement shall be governed by the laws of the State of North Carolina without regard to conflict of laws principles. You and the Licensor hereby consent to the exclusive venue and jurisdiction of the state and federal courts located in Mecklenburg County, North Carolina.

TAXES. You are responsible for all taxes or charges imposed by any government or regulatory authority with respect to the delivery and use of the Software, but exclusive of any taxes based upon the Licensor's net income.

TERM. This License Agreement is effective until terminated. You may terminate this License Agreement by ceasing to use the Software and, if applicable, returning the Software to the Licensor. Licensor may terminate this License Agreement if You breach any of the terms and conditions. Upon termination of this License Agreement for any reason, You shall cease using the Software and, if applicable, return the Software to the Licensor. All provisions of this Agreement relating to disclaimers of warranties, limitation of liability, remedies, or damages, and Licensor's proprietary rights shall survive termination.

ACKNOWLEDGMENTS. The ICC profiles provided by DNP Imagingcomm America Corporation are prepared using the technology of X-Rite, Incorporated. YOU ACKNOWLEDGE YOU HAVE READ AND UNDERSTAND THIS AGREEMENT AND AGREE TO BE BOUND BY ITS TERMS. YOU FURTHER AGREE THAT THIS AGREEMENT IS THE COMPLETE AND EXCLUSIVE STATEMENT OF THE AGREEMENT BETWEEN YOU AND LICENSOR, AND SUPERSEDES ANY PROPOSAL OR PRIOR AGREEMENT, ORAL OR WRITTEN, AND ANY OTHER COMMUNICATIONS RELATING TO THE SOFTWARE ADDRESSED IN THIS AGREEMENT.

The information contained in this document represents the current view of DNP Imagingcomm America Corporation on the issues discussed as of the date of publication. Because DNP Imagingcomm America Corporation must respond to changing market conditions, it should not be interpreted to be a commitment on the part of DNP Imagingcomm America Corporation, and DNP Imagingcomm America Corporation cannot guarantee the accuracy of any information presented after the date of publication. This document is for informational purposes only. DNP Imagingcomm America Corporation MAKES NO WARRANTIES, EXPRESSED OR IMPLIED, AS TO THE INFORMATION IN THIS DOCUMENT.

Complying with all applicable copyright laws is the responsibility of the user. Without limiting the rights under copyright, no part of this document may be reproduced, stored in or introduced into a retrieval system, or transmitted in any form or by any means (electronic, mechanical, photocopying, recording, or otherwise), or for any purpose, without the express written permission of DNP Imagingcomm America Corporation

DNP Imagingcomm America Corporation may have patents, patent applications, trademarks, copyrights, or other intellectual property rights covering subject matter in this document. Except as expressly provided in any written license agreement from DNP Imagingcomm America Corporation, the furnishing of this document does not give you any license to these patents, trademarks, copyrights, or other intellectual property.

WPS-1™, WPS Pro™, Tomo™, Hot Folder Print™, PrintCenter™, DS-Series Printers™, and PrintTurbine™ are trademarks and Nexlab® is a registered trademark of DNP Imagingcomm America Corporation PrintRush® and Party Print® are registered trademarks of Dai Nippon Printing Company LTD. Apple, the Apple logo, iPad, and iPhone are trademarks of Apple Inc., registered in the U.S. and other countries. App Store is a service mark of Apple Inc. Amazon is a trademark of Amazon.com Inc. or its affiliates. Android and Google Play are trademarks of Google, Inc. SD, SDHC and SDXC are trademarks or registered trademarks of SD-3C, LLC in the United States, other countries or both. Sony® and Cyber-shot® are the registered trademarks of the Sony Corporation. FlashAir™ is the trademark of Toshiba Corporation. PiPO™ is the trademark of PiPO Corporation. USPS® is a registered trademark of the United States Postal Service. The names of actual companies and products mentioned herein may be the trademarks of their respective owners.

Image Scaling Utility Class

Copyright (c) 2010, Sony Ericsson Mobile Communication AB. All rights reserved.

Redistribution and use in source and binary forms, with or without modification, are permitted provided that the following conditions are met:

Redistributions of source code must retain the above copyright notice, this list of conditions and the following disclaimer. Redistributions in binary form must reproduce the above copyright notice, this list of conditions and the following disclaimer in the documentation and/or other materials provided with the distribution. Neither the name of the Sony Ericsson Mobile Communication AB nor the names of its contributors may be used to endorse or promote products derived from this software without specific prior written permission.

THIS SOFTWARE IS PROVIDED BY THE COPYRIGHT HOLDERS AND CONTRIBUTORS "AS IS" AND ANY EXPRESS OR IMPLIED WARRANTIES, INCLUDING, BUT NOT LIMITED TO, THE IMPLIED WARRANTIES OF MERCHANTABILITY AND FITNESS FOR A PARTICULAR PURPOSE ARE DISCLAIMED.

IN NO EVENT SHALL THE COPYRIGHT HOLDER OR CONTRIBUTORS BE LIABLE FOR ANY DIRECT, INDIRECT, INCIDENTAL, SPECIAL, EXEMPLARY, OR CONSEQUENTIAL DAMAGES (INCLUDING, BUT NOT LIMITED TO, PROCUREMENT OF SUBSTITUTE GOODS OR SERVICES; LOSS OF USE, DATA, OR PROFITS; OR BUSINESS INTERRUPTION) HOWEVER CAUSED AND ON ANY THEORY OF LIABILITY, WHETHER IN CONTRACT, STRICT LIABILITY, OR TORT (INCLUDING NEGLIGENCE OR OTHERWISE) ARISING IN ANY WAY OUT OF THE USE OF THIS SOFTWARE, EVEN IF ADVISED OF THE POSSIBILITY OF SUCH DAMAGE.

Boost Software License - Version 1.0 - August 17th, 2003

Permission is hereby granted, free of charge, to any person or organization obtaining a copy of the software and accompanying documentation covered by this license (the "Software") to use, reproduce, display, distribute, execute, and transmit the Software, and to prepare derivative works of the Software, and to permit third-parties to whom the Software is furnished to do so, all subject to the following:

The copyright notices in the Software and this entire statement, including the above license grant, this restriction and the following disclaimer, must be included in all copies of the Software, in whole or in part, and all derivative works of the Software, unless such copies or derivative works are solely in the form of machine-executable object code generated by a source language processor.

THE SOFTWARE IS PROVIDED "AS IS", WITHOUT WARRANTY OF ANY KIND, EXPRESS OR IMPLIED, INCLUDING BUT NOT LIMITED TO THE WARRANTIES OF MERCHANTABILITY, FITNESS FOR A PARTICULAR PURPOSE, TITLE AND NON-INFRINGEMENT. IN NO EVENT SHALL THE COPYRIGHT HOLDERS OR ANYONE DISTRIBUTING THE SOFTWARE BE LIABLE FOR ANY DAMAGES OR OTHER LIABILITY, WHETHER IN CONTRACT, TORT OR OTHERWISE, ARISING FROM, OUT OF OR IN CONNECTION WITH THE SOFTWARE OR THE USE OR OTHER DEALINGS IN THE SOFTWARE.

This copy of the libpng notices is provided for your convenience. In case of any discrepancy between this copy and the notices in the file png.h that is included in the libpng distribution, the latter shall prevail.

COPYRIGHT NOTICE, DISCLAIMER, and LICENSE:

If you modify libpng you may insert additional notices immediately following this sentence.

This code is released under the libpng license.

libpng versions 1.0.7, July 1, 2000 through 1.6.29, March 16, 2017 are Copyright (c) 2000-2002, 2004, 2006-2017 Glenn Randers-Pehrson, are derived from libpng-1.0.6, and are distributed according to the same disclaimer and license as libpng-1.0.6 with the following individuals added to the list of Contributing Authors:

Simon-Pierre Cadieux

Eric S. Raymond

Mans Rullgard

Cosmin Truta

Gilles Vollant
 James Yu
 Mandar Sahastrabuddhe
 Google Inc.
 Vadim Barkov

and with the following additions to the disclaimer:

There is no warranty against interference with your enjoyment of the library or against infringement. There is no warranty that our efforts or the library will fulfill any of your particular purposes or needs. This library is provided with all faults, and the entire risk of satisfactory quality, performance, accuracy, and effort is with the user.

Some files in the "contrib" directory and some configure-generated files that are distributed with libpng have other copyright owners and are released under other open source licenses.

libpng versions 0.97, January 1998, through 1.0.6, March 20, 2000, are Copyright (c) 1998-2000 Glenn Randers-Pehrson, are derived from libpng-0.96, and are distributed according to the same disclaimer and license as libpng-0.96, with the following individuals added to the list of Contributing Authors:

Tom Lane
 Glenn Randers-Pehrson
 Willem van Schaik

libpng versions 0.89, June 1996, through 0.96, May 1997, are Copyright (c) 1996-1997 Andreas Dilger, are derived from libpng-0.88, and are distributed according to the same disclaimer and license as libpng-0.88, with the following individuals added to the list of Contributing Authors:

John Bowler
 Kevin Bracey
 Sam Bushell
 Magnus Holmgren
 Greg Roelofs
 Tom Tanner

Some files in the "scripts" directory have other copyright owners but are released under this license.

libpng versions 0.5, May 1995, through 0.88, January 1996, are Copyright (c) 1995-1996 Guy Eric Schalnat, Group 42, Inc.

For the purposes of this copyright and license, "Contributing Authors" is defined as the following set of individuals:

Andreas Dilger
 Dave Martindale
 Guy Eric Schalnat
 Paul Schmidt
 Tim Wegner

The PNG Reference Library is supplied "AS IS". The Contributing Authors and Group 42, Inc. disclaim all warranties, expressed or implied, including, without limitation, the warranties of merchantability and of fitness for any purpose. The Contributing Authors and Group 42, Inc.

assume no liability for direct, indirect, incidental, special, exemplary, or consequential damages, which may result from the use of the PNG Reference Library, even if advised of the possibility of such damage.

Permission is hereby granted to use, copy, modify, and distribute this source code, or portions hereof, for any purpose, without fee, subject to the following restrictions:

- 1. The origin of this source code must not be misrepresented.*
- 2. Altered versions must be plainly marked as such and must not be misrepresented as being the original source.*
- 3. This Copyright notice may not be removed or altered from any source or altered source distribution.*

The Contributing Authors and Group 42, Inc. specifically permit, without fee, and encourage the use of this source code as a component to supporting the PNG file format in commercial products. If you use this source code in a product, acknowledgment is not required but would be appreciated.

END OF COPYRIGHT NOTICE, DISCLAIMER, and LICENSE.

TRADEMARK:

The name "libpng" has not been registered by the Copyright owner as a trademark in any jurisdiction. However, because libpng has been distributed and maintained world-wide, continually since 1995, the Copyright owner claims "common-law trademark protection" in any jurisdiction where common-law trademark is recognized.

OSI CERTIFICATION:

Libpng is OSI Certified Open Source Software. OSI Certified Open Source is a certification mark of the Open Source Initiative. OSI has not addressed the additional disclaimers inserted at version 1.0.7.

EXPORT CONTROL:

The Copyright owner believes that the Export Control Classification Number (ECCN) for libpng is EAR99, which means not subject to export controls or International Traffic in Arms Regulations (ITAR) because it is open source, publicly available software, that does not contain any encryption software. See the EAR, paragraphs 734.3(b)(3) and 734.7(b).

Glenn Randers-Pehrson

glennrp at users.sourceforge.net

March 16, 2017

*DNP Imagingcomm America Corporation * 4524 Enterprise Dr NW * Concord, NC 28027 * USA*

© 2000-2017 DNP Imagingcomm America Corporation All rights reserved.

Compliance Notices

WARNING: Changes or modifications not expressly approved by the party responsible for compliance could void the user's authority to operate the equipment under FCC rules.

This equipment has been tested and found to comply with the limits for a Class B digital device, pursuant to Part 15 of the FCC Rules. These limits are designed to provide reasonable protection against harmful interference in a residential installation. This equipment generates, uses and can radiate radio frequency energy and, if not installed and used in accordance with the instructions, may cause harmful interference to radio communications. However, there is no guarantee that interference will not occur in a particular installation. If this equipment does cause harmful interference to radio or television reception, which can be determined by turning the equipment off and on, the user is encouraged to try to correct the interference by one or more of the following measures:

- Reorient or relocate the receiving antenna.
- Increase the separation between the equipment and receiver.
- Connect the equipment into an outlet on a circuit different from that to which the receiver is connected.
- Consult the dealer or an experienced radio/TV technician for help.

This equipment complies with FCC radiation exposure limits set forth for an uncontrolled environment. This equipment is in direct contact with the body of the user under normal operating conditions. This transmitter must not be co-located or operating in conjunction with any other antenna or transmitter.

Under Industry Canada regulations, this radio transmitter may only operate using an antenna of a type and maximum (or lesser) gain approved for the transmitter by Industry Canada. To reduce potential radio interference to other users, the antenna type and its gain should be so chosen that the equivalent isotropically radiated power (e.i.r.p.) is not more than that necessary for successful communication. This is a controlled document. To be sure you have the latest version of this Procedure, compare this document revision to the revision listed in the Document Control database. If you find this document is not current, discard and get the latest version from the Document Control database.

Conformément à la réglementation d'Industrie Canada, le présent émetteur radio peut fonctionner avec une antenne d'un type et d'un gain maximal (ou inférieur) approuvé pour l'émetteur par Industrie Canada. Dans le but de réduire les risques de brouillage radioélectrique à l'intention des autres utilisateurs, il faut choisir le type d'antenne et son gain de sorte que la puissance isotrope rayonnée équivalente (p.i.r.e.) ne dépasse pas l'intensité nécessaire à l'établissement d'une communication satisfaisante.

NOM 121 – La operación de este equipo está sujeta a las siguientes dos condiciones: (1) es posible que este equipo o dispositivo no cause interferencia perjudicial y (2) este equipo o dispositivo debe aceptar cualquier interferencia, incluyendo la que pueda causar su operación no deseada.

Importer:

DNP NA
Le Raphael Paris Nord 2 22 Avenue de Nations BP 51077
Villepinte, 95948 ROISSY CH DE GAULLE CEDEX, FRANCE

Manufacturer:

PIPO Technology Co., Ltd.
c/o DNP Imagingcomm America Corporation
4524 Enterprise Drive NW
Concord, NC 28027 United States

If you want to dispose of this product, do not mix with general household waste. There is a separate collection system for used electronics products in accordance with legislation under the WEEE Directive. For details, please consult with your dealer.

PIPO Technology Co., Ltd. hereby declares that this Wireless Print Server is in compliance with the essential requirements and other relevant provisions of Directive 1999/5/EC. For details, please access the URL: <http://www.dnpphoto.eu/en/>

Par la présente PIPO Technology Co., Ltd. déclare que l'appareil est conforme aux exigences essentielles et aux autres dispositions pertinentes de la directive 1999/5/CE. Pour toute information complémentaire, veuillez consulter l'URL suivante: <http://www.dnpphoto.eu/fr/>

Hiermit erklärt PIPO Technology Co., Ltd., dass sich das Gerät Wireless Print Server in Übereinstimmung mit den grundlegenden Anforderungen und den übrigen einschlägigen Bestimmungen der Richtlinie 1999/5/EG befindet. Weitere Informationen erhältlich unter: <http://www.dnpphoto.eu/de/>

Por medio de la presente PIPO Technology Co., Ltd. declara que el Wireless Print Server cumple con los requisitos esenciales y cualesquiera otras disposiciones aplicables o exigibles de la Directiva 1999/5/CE. Para mayor información, por favor consulte el siguiente URL: <http://www.dnpphoto.eu/es/>

Con la presente PIPO Technology Co., Ltd. dichiara che questo Wireless Print Server è conforme ai requisiti essenziali ed alle altre disposizioni pertinenti stabilite dalla direttiva 1999/5/CE. Per ulteriori dettagli, si prega di consultare il seguente URL: <http://www.dnpphoto.eu/it/>

PIPO Technology Co., Ltd. tímto prohlašuje, že tento Wireless Print Server je ve shodě se základními požadavky a dalšími příslušnými ustanoveními směrnice 1999/5/ES. Podrobnosti lze získat na následující URL: <http://www.dnpphoto.eu/en/>

PIPO Technology Co., Ltd. vakuuttaa täten että Wireless Print Server tyypinen laite on direktiivin 1999/5/EY oleellisten vaatimusten ja sitä koskevien direktiivin muiden ehtojen mukainen. Halutessasi lisätietoja, käy osoitteessa: <http://www.dnpphoto.eu/en/>

Με την παρούσα η PIPO Technology Co., Ltd. δηλώνει ότι Wireless Print Server συμμορφώνεται προς της ουσιώδεις απαιτήσεις και τις λοιπές σχετικές διατάξεις της οδηγίας 1999/5/EK. Για λεπτομέρειες παρακαλούμε όπως ελέγξετε την ακόλουθη σελίδα του διαδικτύου: <http://www.dnpphoto.eu/en/>

Niniejszym PIPO Technology Co., Ltd. oświadcza, że Wireless Print Server jest zgodne z zasadniczymi wymaganiami oraz innymi stosownymi postanowieniami Dyrektywy 1999/5/WE. Szczegółowe informacje znaleźć można pod następującym adresem URL: <http://www.dnpphoto.eu/en/>

PIPO Technology Co., Ltd. declara que este Wireless Print Server está conforme com os requisitos essenciais e outras disposições da Directiva 1999/5/CE. Para mais informações, por favor consulte o seguinte URL: <http://www.dnpphoto.eu/en/>

CONTENTS

1. Before You Begin

Documentation Conventions	11
Text Elements	11
Text Treatments.....	11
Important Safety Instructions	12
General Safety Precautions	12
Contact Us	12

2. Introduction

What is the IDW500?	13
IDW500 System Components	13
IDW500 Console	14
IDW500 Software Applications	14

3. Installation

Preparing the Camera	15
Setting up the Printer	15
Setting Up IDW500 Unit	19
Setting Up the Camera	21

4. Using the IDW500 System

Your Camera Controls	23
Turning ON the System	24
About the ID Photo Application	24
Passport Photo Requirements	29
Taking a Passport Photo	31
Adding a Custom Template	32
Printing an Image	33
About Auto Printing	36
Editing Images	37
Reprinting an Image	38
Erasing Images from the Console	39
Saving Images to a USB Drive	40
Printer Queue	42
Shutting Down the IDW500 System	43
About the IDW500 Configuration Screen	44
Accessing the IDW500 Configuration Screen	44
Behaviors Section.....	45

Imaging Section	46
Print Section.	46
ID Types Section	47
System Section	47
Erasing Images from the Camera	48
Erasing all Images on the Camera	48
Enabling the Flash	48
Printing Directly from the Camera via USB Cable	49
5. Using the IDW500 Printer	
About your Printer	51
Replacing the Printer Media	51
Maintaining the Printer	54
Cleaning the Platen Roller	54
Cleaning the Thermal Print Head	55
Repacking the Printer	56
Troubleshooting Printer Issues	57
Clearing Paper Jams	57
Clearing Ribbon Jams	58
6. Troubleshooting the System	
General Troubleshooting Steps	61
Reconfiguring the SD Card	61
Repairing the SD Card.	61
Setting the ID Number	62

Before You Begin

This chapter explains a little about your IDW500 system and how to use the information in this book to get the most use from your system.

Documentation Conventions

When using this document, several text elements and treatments are repeated throughout. The following is an explanation of these symbols and headings:

Text Elements



Attention

This denotes important information concerning safety when working with the equipment. Failure to comply with an Attention statement can cause you injury or harm or cause damage to the system.



Note

This signifies convenient or useful instructions.



Used to denote a procedure that requires two people to lift a heavy item.



Warns of a time-sensitive step. Be sure to read the surrounding instructions completely before performing this operation.



Signifies an item that needs to be entered on the specified form.

Text Treatments

Bold Text – Indicates items you can select, such as buttons and menu entries.

Italic Text – Indicates variable text or placeholders for information, such as user names and directory paths. When entering directory paths and so forth, the word in italics should not be typed, but should be replaced by the appropriate text. Italic text also introduces new words and is occasionally used for emphasis in text.

Monospace– Distinguishes information that is displayed on the screen, as well as the text that you should enter.

Important Safety Instructions

Safety is paramount when installing and operating the system. These safety instructions are to protect you and the customer and the overall public. The following bullet points apply to the safety instructions in this manual:

- ❖ Read all of these instructions before setting up, installing, and operating your system.
- ❖ Follow all warnings, safety precautions, and notices for all procedures in this manual.
- ❖ When in doubt, stop what you are doing and reassess the safety of the situation or procedure. Never continue with a step or procedure when there is the slightest doubt regarding safety.
- ❖ Save these instructions for future reference.

General Safety Precautions

- ❖ Never install or setup the system near water.
- ❖ Never place the system on an unstable platform.
- ❖ Never place the system near a heat source, such as a heater or furnace.
- ❖ Never perform any of these steps while wearing jewelry (rings, loose necklaces, bracelets, etc.), neckties, or other clothing that could get caught in the equipment. These items can get caught in the equipment or may conduct electricity and cause injury.
- ❖ Never insert any foreign object into the system unit without powering the system OFF first.
- ❖ Never block ventilation ports; allow plenty of room around the system for ventilation.
- ❖ Never use water or liquid to extinguish a fire on the system unit.
- ❖ Always protect the power cord from accidental kinks, cuts, and foot traffic.
- ❖ Always operate this system from the correct type of grounded power source.
- ❖ Always clean and maintain the system in the prescribed manner as instructed in this manual.
- ❖ Always use this equipment in the specified manner as recommended by the manufacturer.
- ❖ Failure to observe safety precautions voids your warranty and may cause damage to the unit and could result in personal injury or death.

Contact DNP Imagingcomm America Corporation immediately if:

- ❖ The system is damaged due to fire or flood; or is otherwise unsafe to operate.
- ❖ Any part of the system is dropped, cracked, or is not operating properly after performing cleaning and maintenance.
- ❖ You have any questions not answered in this manual.

Contact Us

Need help? Contact DNP Imagingcomm America Corporation technical support at:

United States Phone: 1.844.367.8777

Email: dnpsupport@dnp.imgcomm.com

Website: www.dnpphoto.com

For hours of operation, see our website.

Introduction

Use this chapter to learn about your new IDW500 system.

What is the IDW500?

The IDW500 is a **wireless passport and ID photo system** designed to easily create and print passport photos for your customers in minutes. In a matter of minutes, you can take a picture, transfer the image to the IDW500 console, approve the image, and have it print. You can also make minor color and rotation adjustments to images when necessary. Using the IDW500 console, monitor your printer for media usage and possible error conditions.

IDW500 System Components

The following components make up the IDW500 system.

- ❖ Sony® DSC-H300 digital camera
- ❖ Toshiba® FlashAir™ SD card
- ❖ 8" wireless console from PiPO Technologies Co, Ltd.
- ❖ IDW500 software (loaded on wireless console)
- ❖ ID Photo Printer (includes ribbon and paper)



Using the IDW500 system, you can:

- ❖ Make passport or ID photo prints. And depending on the country selected, you can also make visa, resident and citizenship, or other regional or custom photo prints.
- ❖ Edit images to improve the quality of the passport or ID photo.
- ❖ Monitor your printer for errors and low media warnings.

IDW500 Console

Use the image below to identify all of the necessary ports on the IDW500 console.

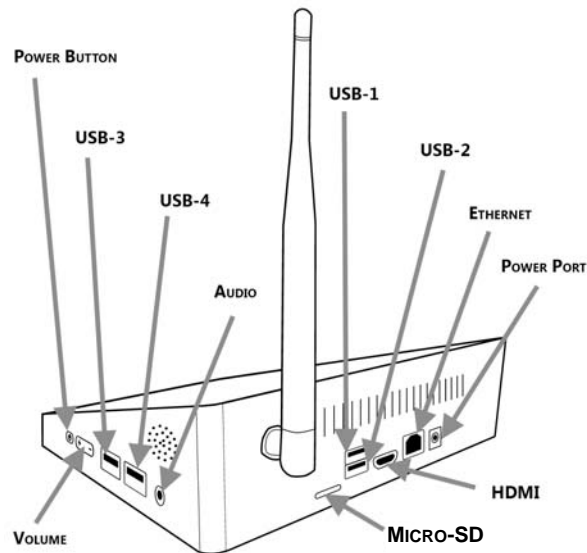

IDW500 Software Applications

While some software applications, or apps, will be used daily, other apps should only be used under the direction of DNP Imagingcomm America Corporation Technical Support.

The IDW500 system is comprised of the following software applications:

❖ Applications for normal, daily use:

- ◆ **ID Photo**: Used to view images and make prints.
- ◆ **Status**: Monitor your IDW500 system as a whole. You can view and reprint up to the last six (6) printed images, view information about your printer, and keep your system running smoothly.



Attention

While the following applications are running on your system, it is not recommended that you use these applications unless you are instructed to do so by technical support. Changing settings in any of these applications can cause system errors and failures.

❖ Applications for troubleshooting or system maintenance.

- ◆ **IDW500 Maintenance**: Used in conjunction with DNP Imagingcomm America Corporation Technical Support to troubleshoot issues with the system. Also used to reboot or power OFF your IDW500 system.
- ◆ **IDW500 Configuration**: Make configuration changes to the IDW500 software such as turning the sounds off, or adjusting other inputs.

Installation

Preparing the Camera

1. Remove the camera from the shipping box. Be sure to remove any packaging material from the camera.
2. The camera batteries must be charged prior to use. Use the supplied battery charger and allow at least 2 hours to fully charge the batteries before proceeding.
3. Make sure your camera LCD screen is clean.
4. Locate the photo template stickers and select the template that aligns properly with your camera LCD screen.
5. Carefully apply the photo template sticker to the camera. Working from the center of the sticker, slowly press outwards to remove any wrinkles or bubbles. Go slowly to minimize air bubbles.

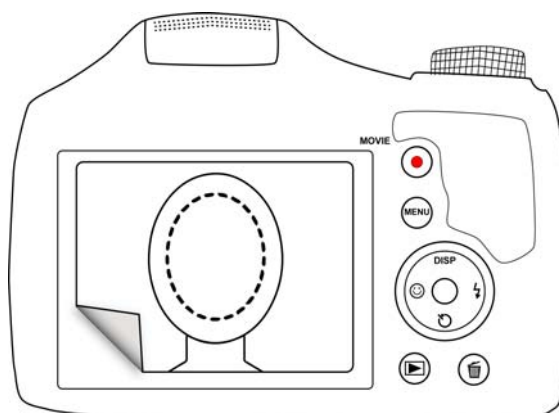

Figure 1. Applying the photo template sticker to the LCD screen.

6. Connect the camera strap and the lens lanyard to the camera.
7. Set the camera aside while the batteries charge so that you can set up the rest of your IDW500 system.

Setting up the Printer

1. Remove your new printer from the shipping box. Open the box and remove any packaging material from the outside of the printer.
2. Place the printer on the work surface. Make sure that the printer is not tilted or unsteady.
3. Plug the power cord into the back of the printer. Do not plug the power cord into the wall until later.

4. Plug the USB cable into the back of the printer.

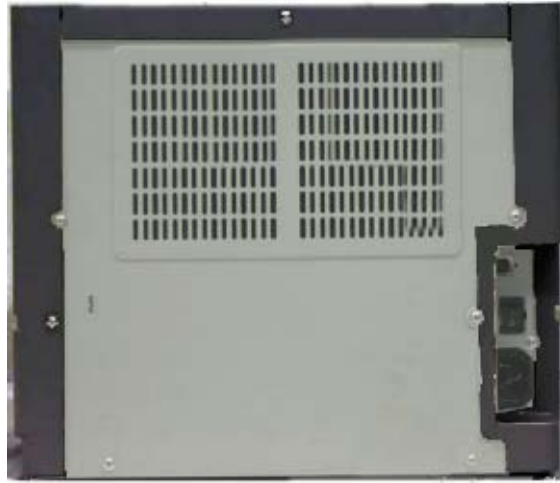

5. Press the release lever on the top, front of the printer to open the printer media compartment door.



- Remove the print head protection foam block and save it with the shipping box.



- Remove the paper spools from the printer paper compartment. Set the spools aside until you are ready to load your paper. Be sure to remove any other packaging material from inside the printer.



Attention

Be sure to save your shipping box! If you ever need to move your printer to a new location or send your printer in for repairs, the original shipping box is the safest packing option. Just put the packaging materials (including the print head protection foam block) back in the box and store it in a safe place.

- Plug the printer power cord into the wall outlet. Power the printer ON. The printer lights will flash and the printer will beep as it initializes.
- Locate your box of printer media (paper and ribbon). Open the box and remove the paper roll from the box. Remove any packaging (plastic bags and spool plugs) from the paper roll.
- Using the spools you unloaded from your printer, load your paper roll onto the paper spools. Make sure that there are no gaps between the edge of the paper roll and the spools.

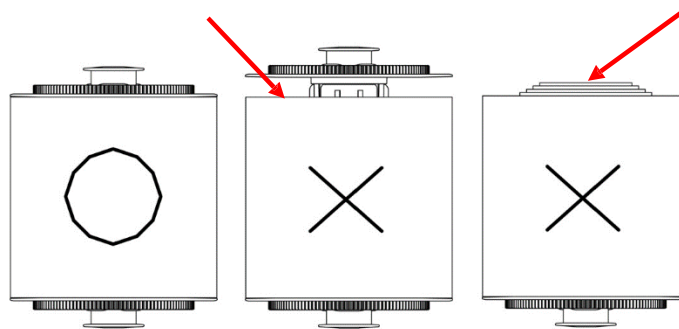

- Place the paper into the printer so that the leading edge of the paper feeds over the top of the roll and into the paper feed path. Remove the PULL tab from the paper roll.
- Feed the paper roll into the paper feed path in the printer. Use the image below to properly feed the paper. Align the paper edges with the PC lines on the printer chassis.

13. Feed the paper under the black guide roller. Continue to feed the paper until the printer beeps. This means that the paper is in the correct position.

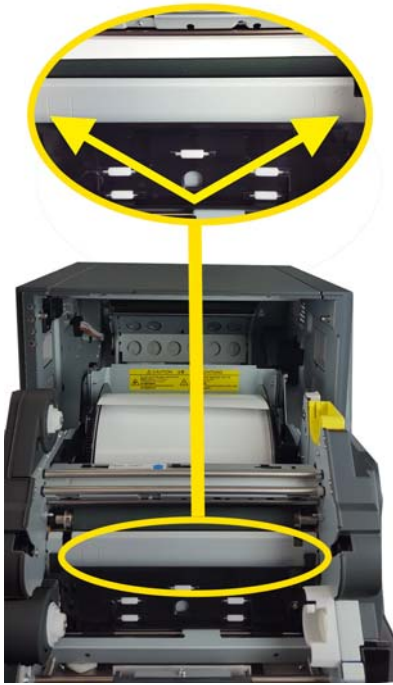

14. Set the ribbon supply side (two white ends) in the lower, or front, brackets. Set the take-up side (one white and one yellow end) in the upper, or back, brackets. Insert the left side of the ribbon spool into place first, then snap the right side of the spool into place. Wind the take-up spool to remove any slack in the ribbon. The supply spool feeds over the top while the take-up spool feed underneath.



15. Close the printer door. The printer will initialize, and 5 blank sheets of paper will be ejected.

16. Place the scrap box on the front of the printer.



17. Place the print catch tray on the front of the printer.

Setting Up IDW500 Unit

1. Unpack the IDW500 console from the shipping box.
2. Remove any protective plastic or foam from the unit.
3. Plug the printer USB cable into the bottom port on the back of the IDW500 unit.

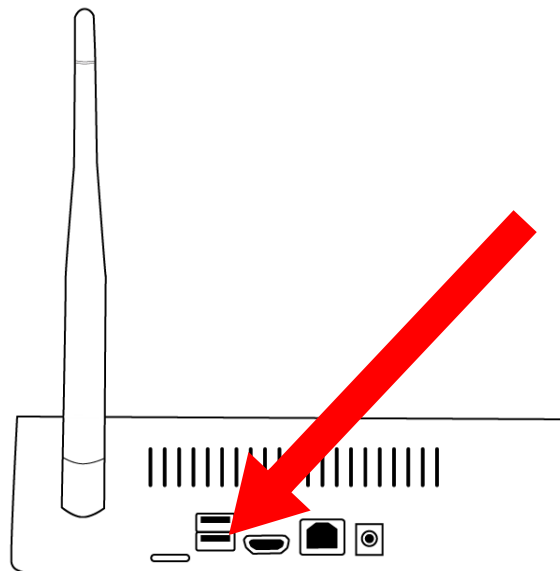

4. Plug the power cord into the IDW500 unit and into a wall outlet.

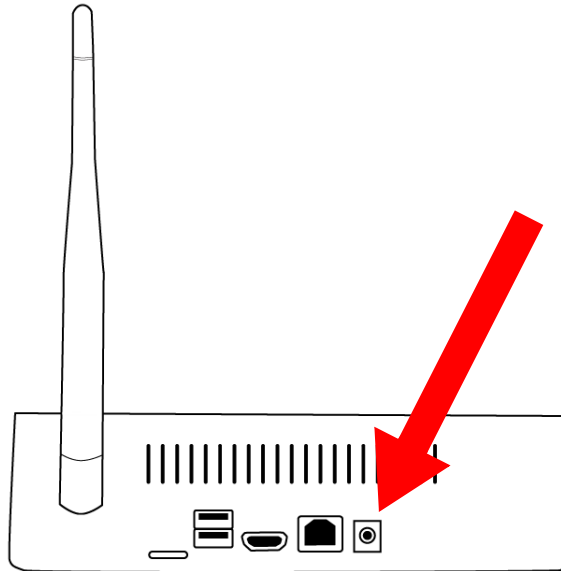

5. Press the power button on the right side of the console to power ON your system. Hold the power button until the unit powers on. (This may take a few seconds.)

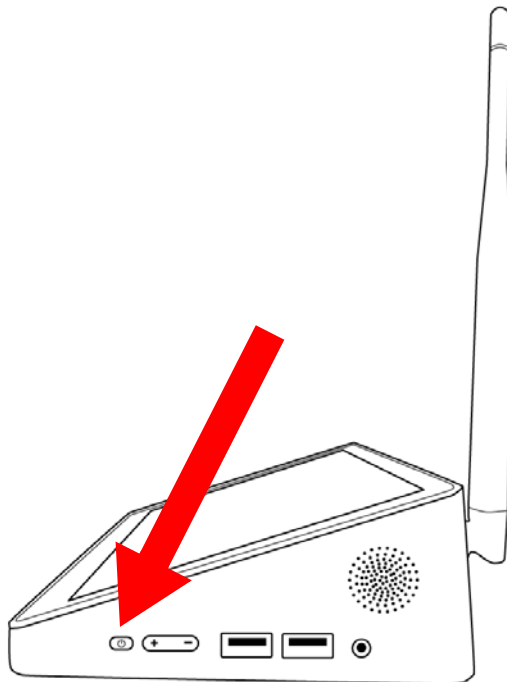

6. Once the system is running, a test page is printed. It takes about two minutes for the system to initialize. When the test print is printed, it will display the media count, i.e. how many images have been printed so far.

**Note**

USB compatible devices, such as keyboards and mice, are not supported for use with the IDW500 console.

Setting Up the Camera

1. Install the fully charged batteries in the camera.

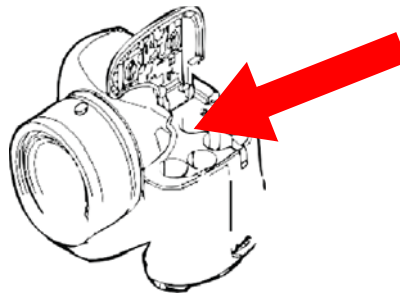

2. Locate the Toshiba FlashAir™ card that came with the kit. Install the card in the camera.
3. Power the camera ON.
4. Once the setup menu appears, follow the prompts on the camera to enter the time and date information.
5. Press the **MENU** button and set file size to 5 mega pixels.

**Note**

Use the 5 mega pixel image size for optimum performance of the system. Using a larger image size can slow system processing times and will not improve image quality. Using a smaller image size can cause lowered image quality.

6. When you are done, press the **PLAYBACK** button to exit the setup menu. You are now ready to take ID photos!

**Note**

The camera and card may take up to two (2) minutes to sync up with the console. Upon syncing up with the camera, your console briefly displays a "Camera Found" message.

Using the IDW500 System

Your Camera Controls

Use the diagram below to identify the areas of your passport camera you will use with the IDW500 system. While there are more settings and functions available on your camera, DNP Imagingcomm America Corporation recommends not changing other settings without first consulting Technical Support. For more information about other settings and camera controls, see your camera user manual.

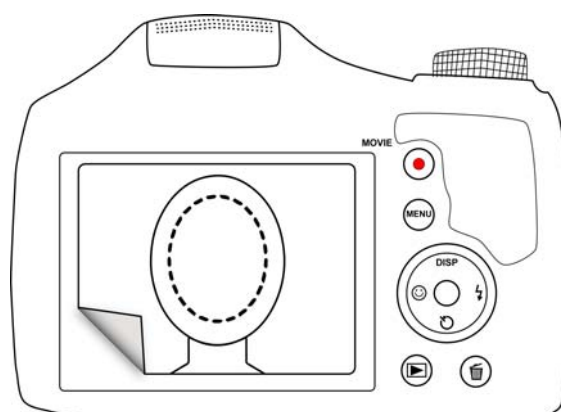

- ❖ **LCD Viewer:** The large view area on the back of the camera. Use the LCD viewer to preview your passport photos prior to sending the image to the IDW500 console for printing. The template overlay sticker allows you to take perfectly aligned ID photos every time.
- ❖ **Control Wheel:** The control wheel – to the right of the LCD viewer – is used to access many camera functions. Use the wheel to access menus as well as to move within menus. For the purposes of this document, the ▶ ▲ ▼ and ◀ icons (right, up, down, and left) will be used to demonstrate moving within menus. The **SELECT** button is the button in the middle of the control wheel.
- ❖ **Playback Button:** Opens the playback screen - where images you have taken are displayed for your review.
- ❖ **Menu Button:** Accesses the main camera menu. Use this button to send images to the IDW500 console via the DPOF transfer method.

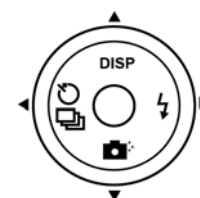

Turning ON the System

You must power ON the system in the following order:

1. **Printer** (wait for the ready light on the front of the printer before continuing).
2. **IDW500 Console.** The power button is on the right side (wait for the ID Photo application to appear and the test print before continuing).
3. **Camera** (when the IDW500 console beeps and displays a **CAMERA FOUND** message, the camera has been recognized as connected to the network).



Note

If you hear a “beep” after starting the system, check the console for an error message. Typical error messages are **PRINTER NOT FOUND** (verify the printer is ON and plugged into the IDW500 console) or **MEDIA MISMATCH** (the wrong media is loaded in the printer.)

About the ID Photo Application

The ID Photo application is the most-used application on your system. When making prints, you can view the image using this app, and you can also see basic system status information.

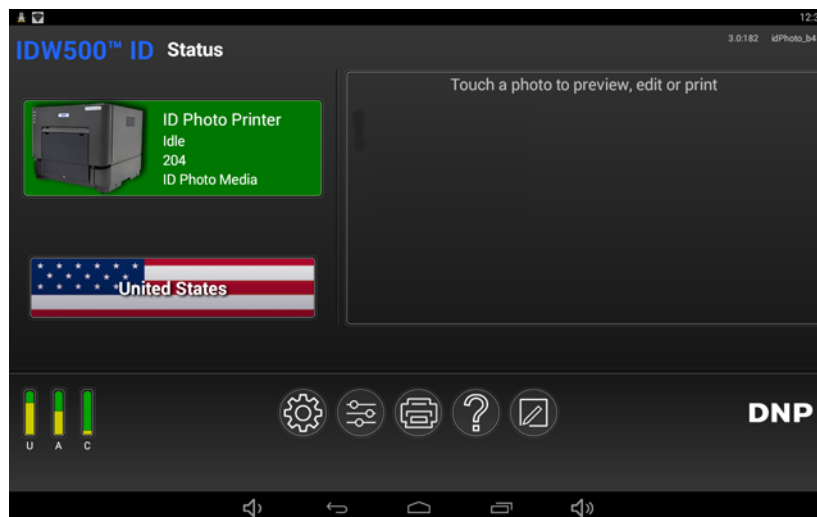

1. The application is automatically started once the system is powered ON. This is the default application that is shown while in use. To view information about your printer, simply look at your main screen. A printer icon is shown that tells

you the current printer status and how many prints are left on the current paper roll. The console's SSID is also displayed in the upper right corner.

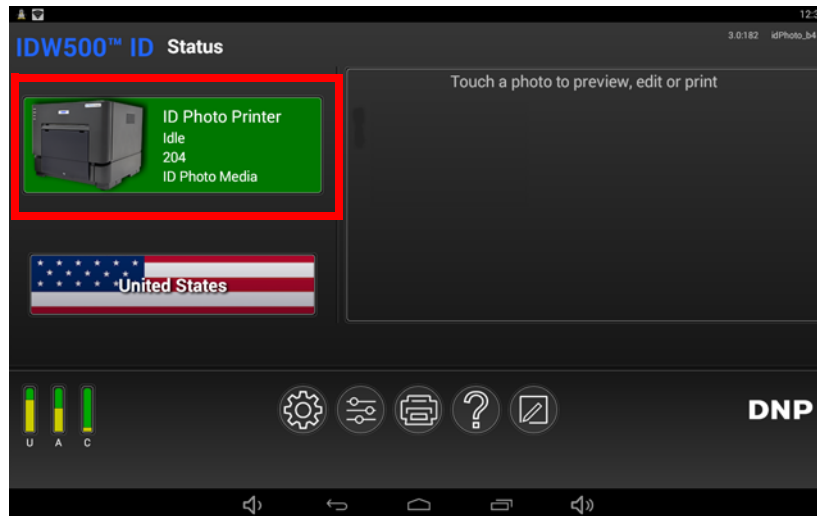

Touching the printer icon flips it over to provide the following additional information:

- ❖ **Name:** The name of the printer attached to your IDW500 console.
- ❖ **Status:** Shows whether your system is idle, printing an image, etc.
- ❖ **Media Left:** Displays the remaining media amount for the printer.
- ❖ **Media Type:** Type of media loaded in your printer.
- ❖ **Paper Type:** Type/size of the paper loaded into your printer.
- ❖ **Life Counter:** Total prints that have been produced by the connected printer in the printer's lifetime.
- ❖ **Firmware Version:** The version of the printer software installed on that printer.
- ❖ **Color Data Version:** The color data version loaded on the printer.

Name	ID Photo Printer
Status	Idle
Media Left	104
Media Type	SD
Paper Type	ID Photo Media
Life Counter	128
Firmware Version	DS-RX1 02.04
Color Data Version	DS-RX1_300_0201.CWD (7CED)

2. You can also print photos for different countries' passports, visas, and other forms of ID by simply touching the **Country** button. Then select the country and type of ID you are creating from the list of available countries. The countries you most frequently use are displayed at the top of the list for easier access.

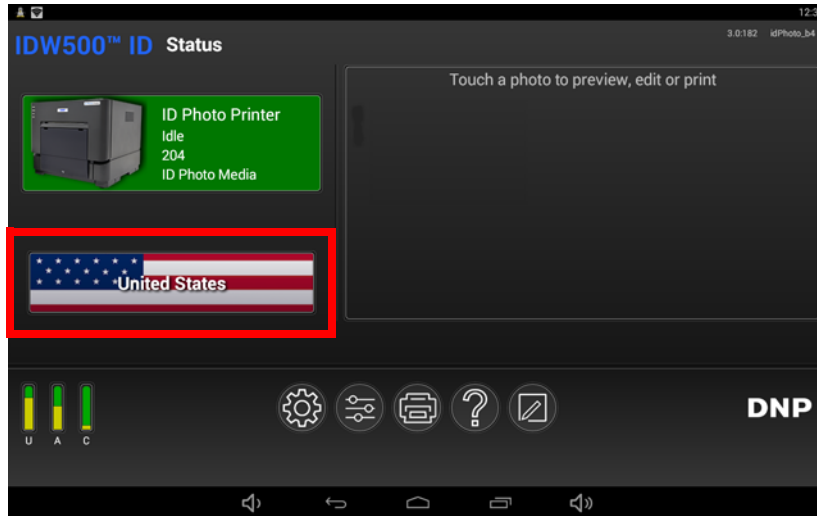

3. At the bottom of the main ID Photo screen, look for the **CAMERA FOUND** message when you're ready to take a passport photo. When you're transferring images for printing, this same area is used to show progress messages.
4. Your IDW500 also retains the last six (6) images printed and displays them on the console monitor. This allows you to reprint recently taken images without having to resend them to the console. As new images are sent for printing, older images are automatically removed from the console on a first in, first out (FIFO) basis.

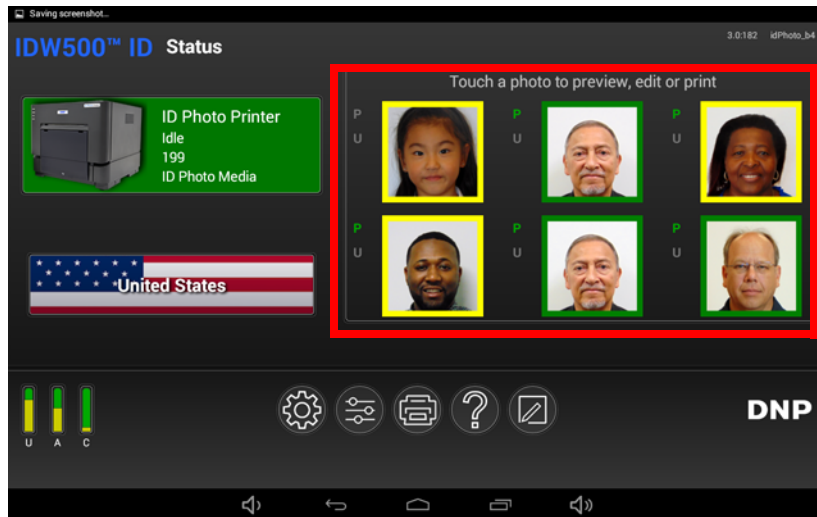

Note

Notice that each image has either a Green or Yellow border around it. The Green border designates that the image has passed all of the Biometrics requirements. The Yellow border designates that the image needs to be checked for one or more of the Biometrics requirements. The thumbnail border is a preliminary indicator of whether the image will pass the biometric screening. Always click on the image to view the final biometric results.

- The images that are displayed on your console monitor displays whether the particular image has been printed or copied to a USB drive. Each image has a letter **P** and a letter **U** next to it; the **P** stands for **Printed** and the **U** stands for **USB**. If the image was printed, the letter **P** is green; if the image was saved to a USB drive, the **U** is green.

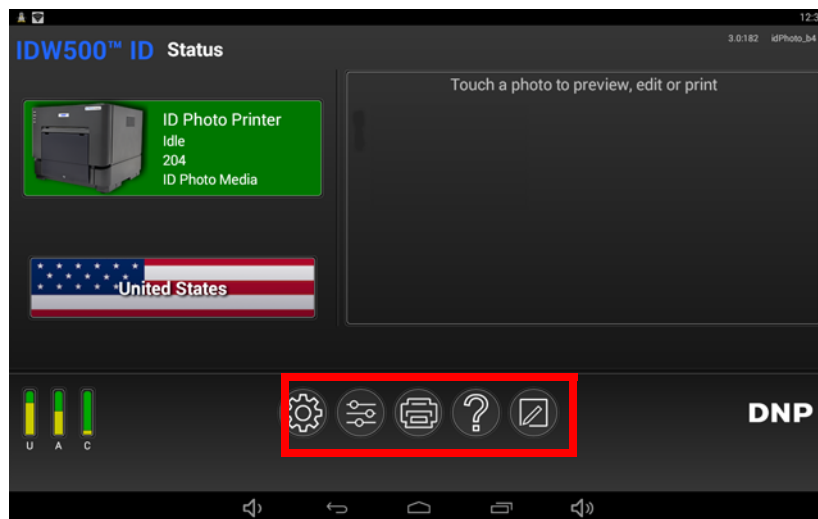
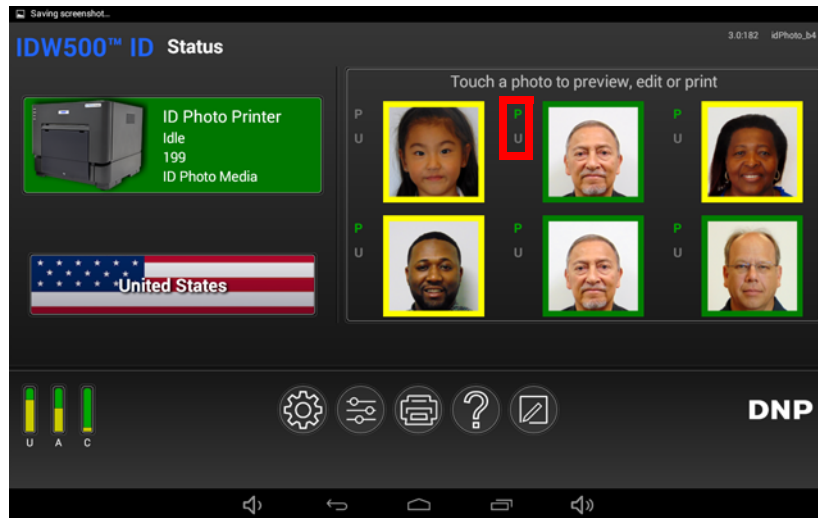

- There are three (3) bars in the lower left corner of the console's main screen. These are free space indicators, letting you know how much free space is left on the console's Unix System (**U**), the console's Android System (**A**) and the Camera (**C**).

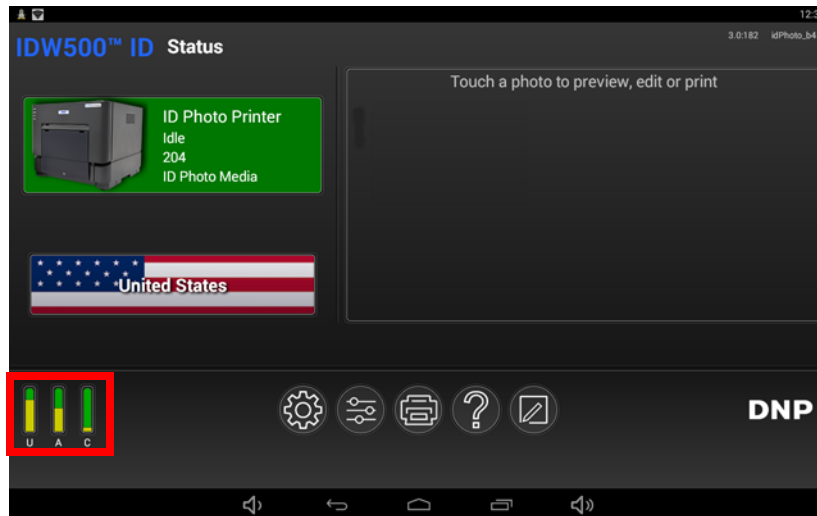

Passport Photo Requirements

The official United States passport requirements state the following:

- ◆ Photo must be 2 inches by 2 inches.
- ◆ The height of the head (top of hair to bottom of chin) should measure 1 inch to 1 3/8 inches (25 mm - 35 mm).
- ◆ Make sure the eye height is between 1 1/8 inches to 1 3/8 inches (28 mm – 35 mm) from the bottom of the photo.

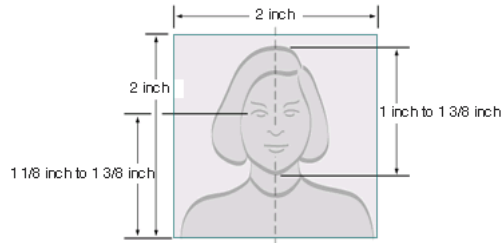

- ◆ Taken with the subject's full face showing towards the camera.
- ◆ Taken with a neutral facial expression (preferred) and with both eyes open.
- ◆ Taken in clothing that the subject would wear on a daily basis:
 - Uniforms, clothing that looks like a uniform, and camouflage attire should not be worn in photos except in the case of religious attire that is worn daily.
 - The subject may only wear a hat or head covering if they wear it daily for religious purposes. Their full face must be visible and any head covering cannot obscure the hairline or cast shadows on the face.
 - Eyeglasses are not accepted unless needed for medical reasons (medical certificate may be required).
- ◆ Headphones, wireless hands-free devices or similar items are not acceptable in the photo.

Use the following guidelines when taking passport photos:

- ◆ Place the subject in front of a white or off-white background with no texture or pattern.



- ◆ Have the subject stand close to the background to minimize shadows.

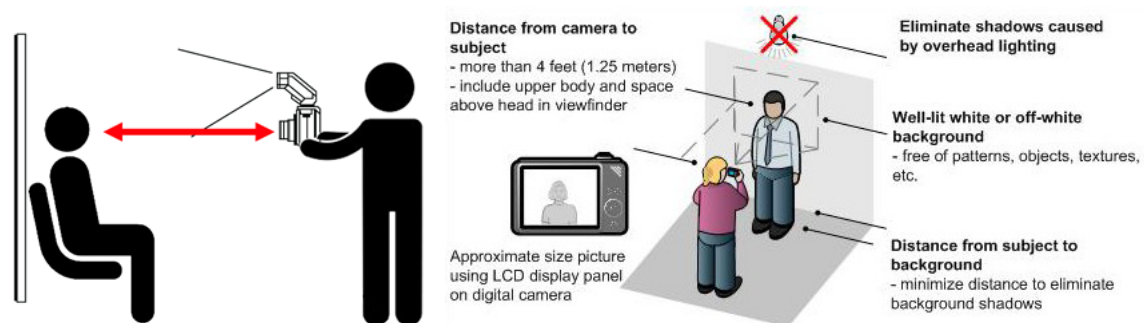

- ◆ Have the subject remove or adjust anything that covers the face – eyeglasses, hats, hair in the face, head coverings in the face. (Have the subject push the head covering out of their face for the picture. The head covering does not need to be removed.)
- ◆ Use the camera flash to reduce shadows if necessary.
- ◆ Stand about 4 - 6 feet away from the subject. Try position the camera so that the camera lens is eye-level with the subject. Use a tripod if possible to get a steady image.
- ◆ Use the zoom function to adjust the subject in the template on the LCD viewer on the camera. The face should fill the dotted oval.
- ◆ Verify that the subject is following all regulations as described in the previous section.
- ◆ Use a flat white screen for the image background. A glossy or reflective screen can cause issues with the flash. If possible, use a screen that is at least 30 inches wide and 48 inches tall.

Taking a Passport Photo

Note

The IDW500 can also be used to take photos for visa, citizenship, other regional or custom IDs, and permanent residency documents, depending on the country you have selected on the main screen of the console.

1. Place the subject in front of a white or very light colored, plain background with no textures or patterns.
2. Have the person stand (or sit) close to the background to minimize shadows.
3. If possible, use photo lights to properly illuminate the subject and further reduce shadows. If necessary, use the camera flash to reduce shadows.
4. Stand 6 feet away from the subject. Hold the camera so that the camera lens is eye-level with the subject.
5. Center the subject's head within the dotted oval on the guide. The head should be as close to the dotted line as possible without going outside of the line. No portion of the subject's head can extend beyond the solid line.

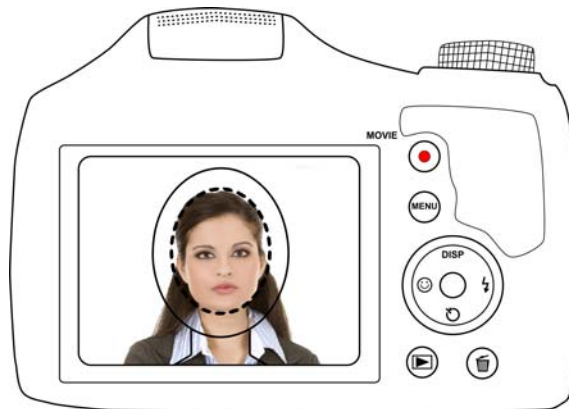

6. Align the top of the subject's head with the top edge of the oval dotted line. Use the zoom function to line up the subject's chin with the bottom edge of the dotted line.
7. Take the picture by pressing the shutter button.
8. Review the photo on the camera LCD. Verify that the subject's head fits within the face guides.

Adding a Custom Template

You can create and save a custom passport or ID template. You can select whether an image appears 2 or 3 times on the print out. You can also set the image size to inches or millimeters, as well as setting the position of your image within the template. Once the template is saved, you can use it over and over again!

1. From the main screen on your console, touch the **Create Template** button.

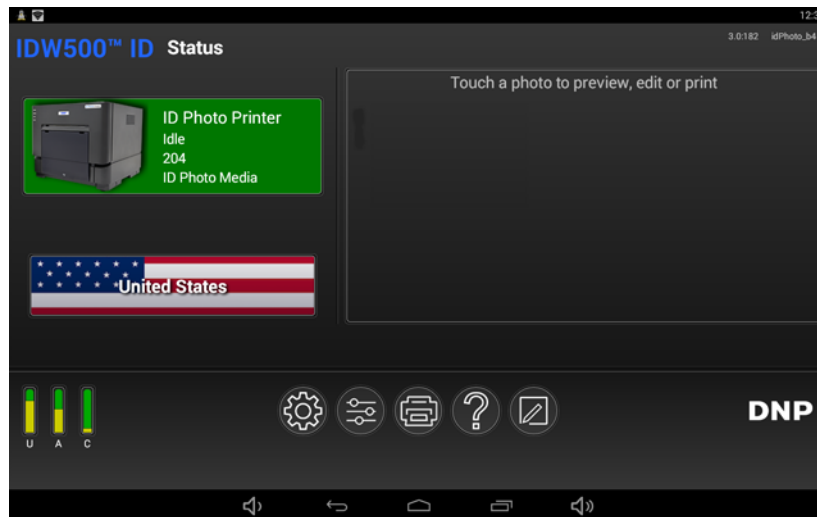

2. Set the **Layout Type**. This allows you to display the image 2 or 3 times on the print out.

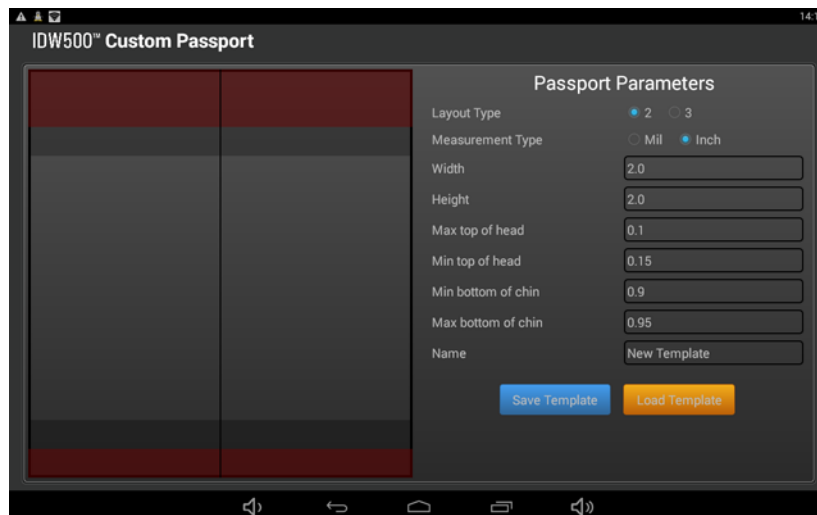

Note

If you select to have three (3) images on your template, you are limited to an image size of 40 millimeters by 40 millimeters.

3. Select the **Measurement Type**. This can be set to **Millimeters** or **Inches**.
4. Set the **Width** and **Height** of the final printed image.

5. Entering percentages in the following fields allows you to set the position of your image within the template. Percentages should be entered as their equivalent; For example, if you wanted to set the **Max top to head** field to 10%, you would enter .10 in this field.
 - ◆ **Max top of head:** The maximum distance the top of the head appears from the top edge of the template.
 - ◆ **Min top of head:** The minimum distance the top of the head appears from the top edge of the template.
 - ◆ **Min bottom of chin:** The minimum distance the bottom of the chin appears from the bottom edge of the template.
 - ◆ **Max bottom of chin:** The maximum distance the bottom of the chin appears from the bottom edge of the template.
6. Type the **Name** of your template
7. Press the **Save Template** button to save your new template.

Printing an Image

1. From the main screen on your console, select the country for which you are printing images. The countries are listed alphabetically, but as you use different countries, the most often used countries will appear at the top of the list.

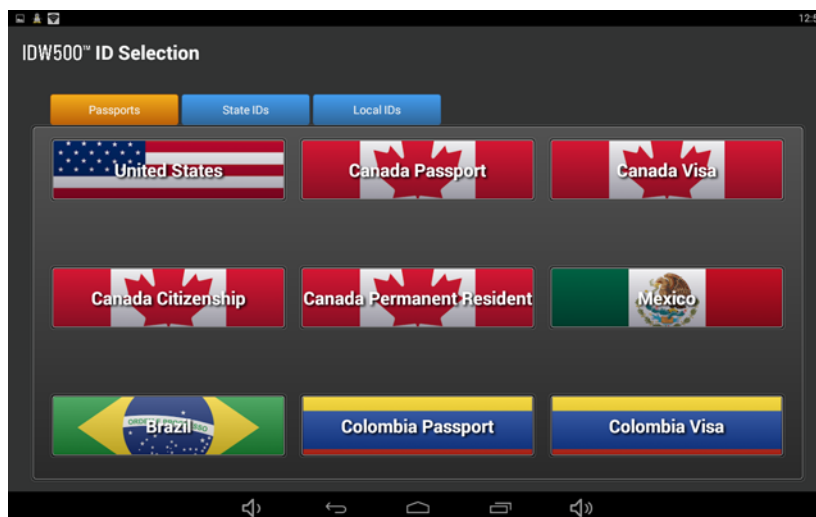

Note

If you wish to use a template you previously created, scroll to the bottom of the country list and select your template. For more information about templates, see “Adding a Custom Template” on page 32.

From the country screen, you can select what kind of ID you wish, i.e., **Passports**, **State IDs**, and **Local IDs**, by selecting those particular tabs. By default, the State ID and Local ID are turned off. If you wish to turn these options on, see “About the IDW500 Configuration Screen” on page 44.

2. If you haven't already, power ON your camera and take the passport photo.
3. Stand no more than 15 feet from your IDW500 console. Listen for the ping to tell you that your camera is connected to the console. If you look at the Photo ID application, you will see a **CAMERA FOUND** message at the bottom of the screen.
4. Press the **PLAYBACK** on the back of the camera.
5. Once the camera is in playback mode, press the **MENU** button.

6. Scroll up ▲ to the **DPOF PRINT** option (the last image is displayed).
7. Press **SELECT**. The image now shows a DPOF tag on the screen.
8. Immediately return to shooting mode. You can press the **SHUTTER** button or the **PLAYBACK** button to do so.



Attention

Do not leave the camera in playback mode. Doing so will cause the image marked as DPOF to be continuously sent to the IDW500 console for printing. Also note, that if multiple images are marked with DPOF, the images will take longer to transfer from the camera to the console. The image begins to transfer. You can hear the sync sounds as the console accepts the image. First, a "ping" occurs as the camera is recognized by the IDW500 console. The console displays a **CAMERA FOUND** message. Next a Electronic sound occurs as the image is transferred – **TRANSFERRING IMAGES** is displayed on the screen. A Pump sound is heard as the console prepares the image for printing – **PROCESSING IMAGES** is displayed.

9. If you hear a Buzzer sound during the image transfer, and **IMAGE REJECTED** is displayed, this means the image was rejected by the console as not meeting the standard passport rules. Re-shoot the image and send the new image for processing.

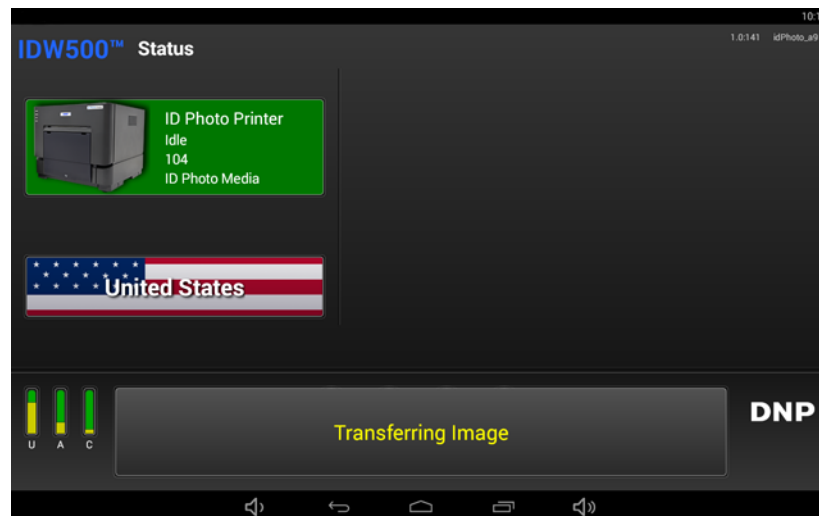

Note

If the image you are sending is not taken at the recommended five (5) mega-pixel size, the transfer will take longer, and you will see a "camera settings" warning on your console's screen. The image can still be printed even if it is above the recommended size.

10. By default, when a print is sent to your console, the image is printed automatically (if it passes all biometric tests) without prompting you. You can change this functionality by turning on the **Confirm Print** option in the Configuration page. If you have this option turned on, continue to step 11. To change this setting, see "About the IDW500 Configuration Screen" on page 44.



Note

You can also have images that do not pass the biometric tests (displayed with a yellow background) print automatically as well. To set this up, see "About the IDW500 Configuration Screen" on page 44.

- When the ID Photo acceptance screen appears, either accept the image as it is by pressing the **ACCEPT** button, or press the **EDIT** button to edit the image. Press **CANCEL** to return to the main ID Photo screen.

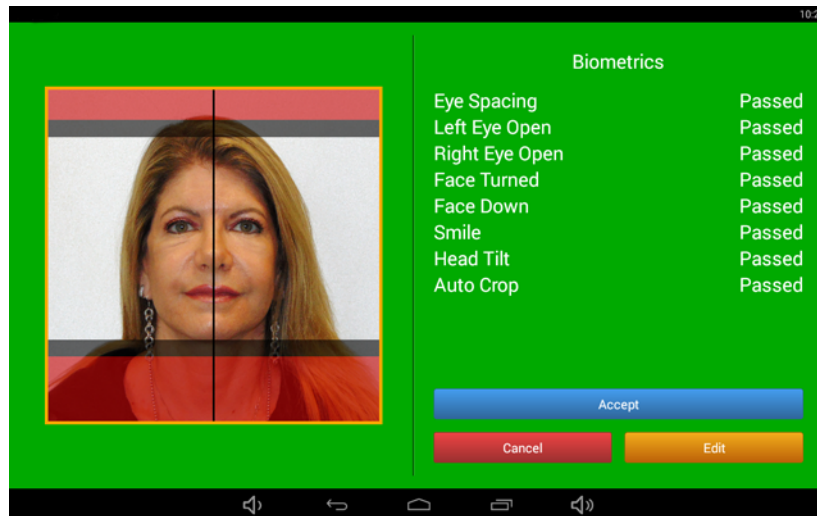

If the photo you have taken has met all of the Biometrics requirements for passport photos, the background of the acceptance screen is displayed as green (image above). If the Biometric requirements have not been met, the background of the acceptance screen is displayed as yellow and the word **Check** appears next to the requirement that failed (image below).

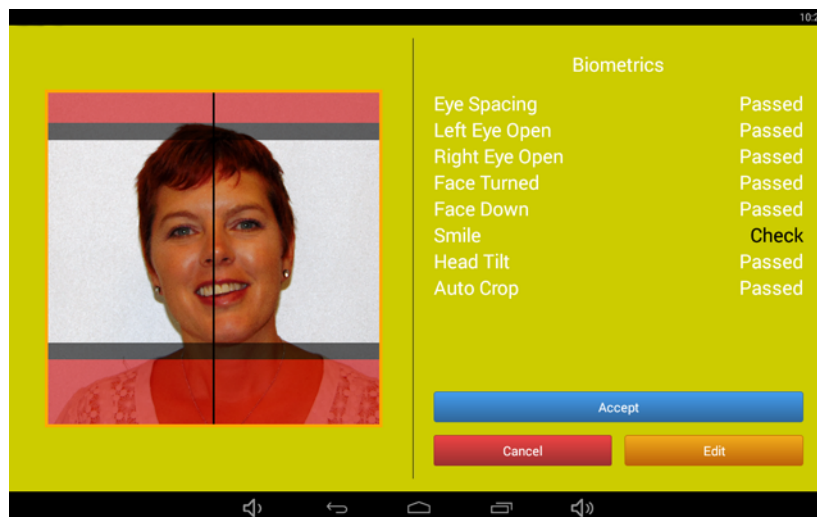

If the image did not pass the Biometrics requirements, touch the **Edit** button and follow the instructions for "Editing Images" on page 37.

12. After pressing the **ACCEPT** button, press the **PRINT** button to print your image or press the **COPY TO USB** button to save your image to a USB drive. If the image was successfully sent to the printer, you will hear a brief Gong sound from your console.

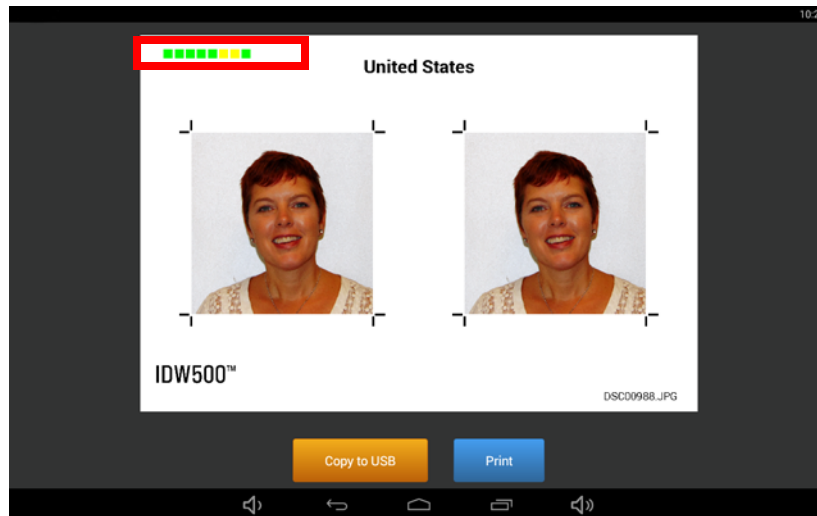

Note

For more information about saving your image to a USB drive, see "Saving Images to a USB Drive" on page 40.

On the above image, you notice a series of eight (8) colored squares in the upper left corner (highlighted by the red rectangle.) Each box refers to one of the Biometric requirements each image must pass. If a particular Biometric requirement was met, the corresponding box appears Green. If a particular Biometric requirement was not met, the corresponding box appears Yellow. The Biometric requirements are as follows:

- ◆ Eyes Spacing
- ◆ Left Eye Open
- ◆ Right Eye Open
- ◆ Face Turned
- ◆ Face Down
- ◆ Smile
- ◆ Head Tilt
- ◆ Auto Crop

Your printer will print out two items: a receipt and the desired image. The receipt contains the biometric test results of the images sent to the printer, as well as a barcode, the country selection for the image, and the date. On the image that is printed, a barcode, the date and the photo size is displayed at the bottom of the print out. The barcode type and data can be set up on the **IDW500 Configuration** screen; see "About the IDW500 Configuration Screen" on page 44.

About Auto Printing

Auto printing can be set up to print only green or both green and yellow images. You can also turn auto-print off, which requires that every image be approved. If you are using the auto-print feature, use the following settings to get the expected results.

- ◆ Strict Biometrics **OFF**, Confirm Print **OFF** - both green and yellow images are auto-printed.
- ◆ Strict Biometrics **ON**, Confirm Print **OFF** - only green images are auto-printed.

- ◆ Confirm Print **ON** - auto-print is disabled, and prints can only be released by the operator.

Editing Images

The editing screen allows you to make minor color, tone, and rotation corrections to an image.

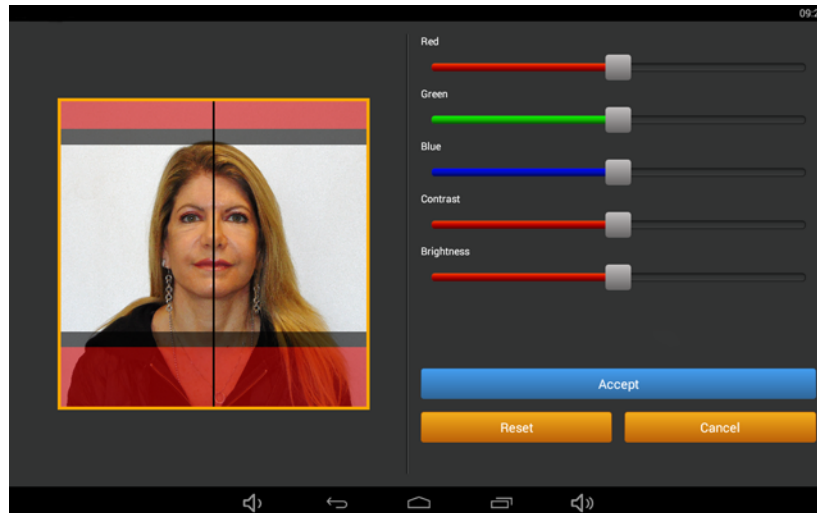

Attention

Only edit images if it is absolutely necessary.

1. From the acceptance screen, press the **EDIT** button.
2. Use the editing screen to make the following changes:
 - ◆ **Color Correction:** If the color is slightly off, correct it using the color sliders. Keep in mind any color correction done will affect the background of the image. Also, make sure your corrections do not distort the skin tone of the subject.
 - ◆ **Brightness/Contrast:** Correct the overall tone of the image using the brightness and contrast settings. Again, take care to not change the skin tone or the background of the image.
3. Make any adjustments that are needed to the image. The vertical line going down the middle of the image is used to center the subject in the template. The black overlay area is within the acceptable tolerance for the ID photo template. The red overlay area is considered out of bounds - none of the subject's face or hair should be in this area.
4. When you have finished editing the image, press **ACCEPT** to print your image. Press **CANCEL** to return to the main screen.



Note

Any adjustments made on this screen are permanent, even after powering off the console. You can also zoom in and out on the image using a pinch zoom function as you would on a smart phone.

Reprinting an Image

Select one of the last six (6) sent images from the image gallery on the console's main screen. Just touch the image you want to reprint and then follow the steps in the previous sections to edit or print the image.

When the image no longer appears as one of the six (6) images in the image gallery, the images have been purged from the console's image cache. Simply resend the image from the camera by selecting the DPOF transfer option again for the image you want to print.



Note

You can also send multiple images back-to-back, and the images will appear in the image gallery as they are processed. If you are using the auto-print feature the images will automatically print as long as all of the biometric feedback criteria is met. Please keep in mind, the image gallery is limited to six (6) images. If more than 6 images are sent at once, the first images sent will be erased from the camera and the image gallery.

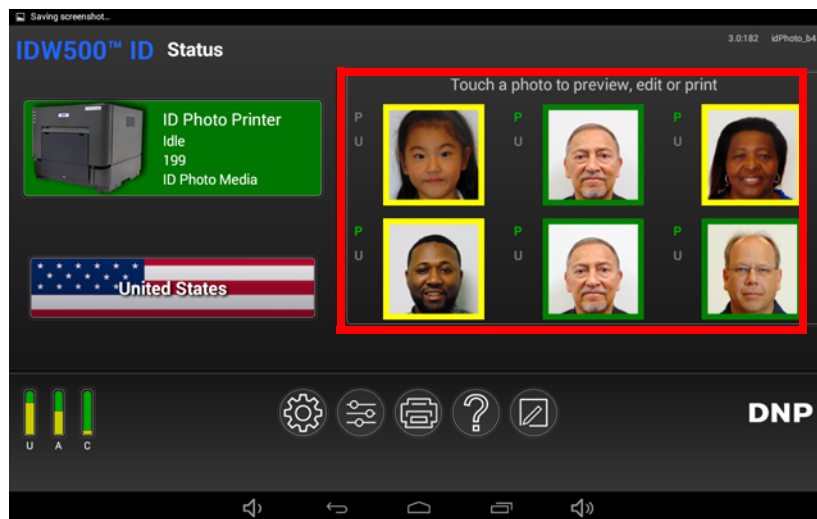

Erasing Images from the Console

You can also delete the images that are displayed on your console.

1. From the main ID Photo screen, press the **GEAR** icon

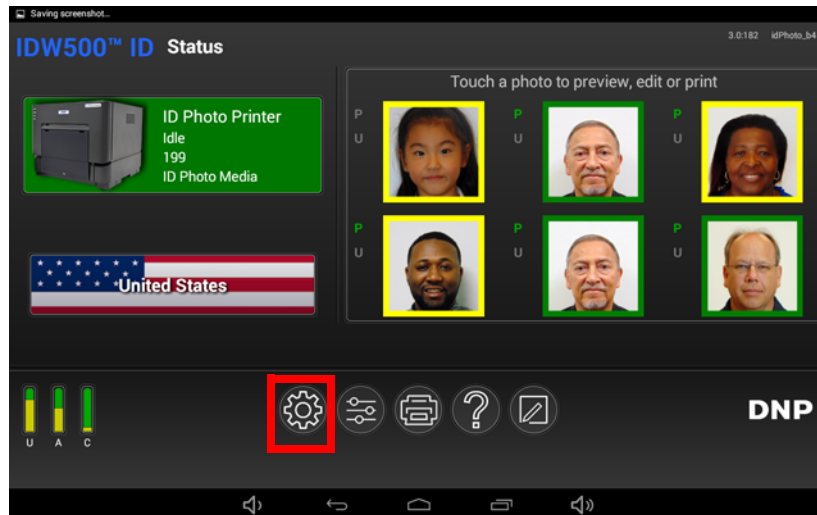

2. Touch the **Clear Image Queue** button.

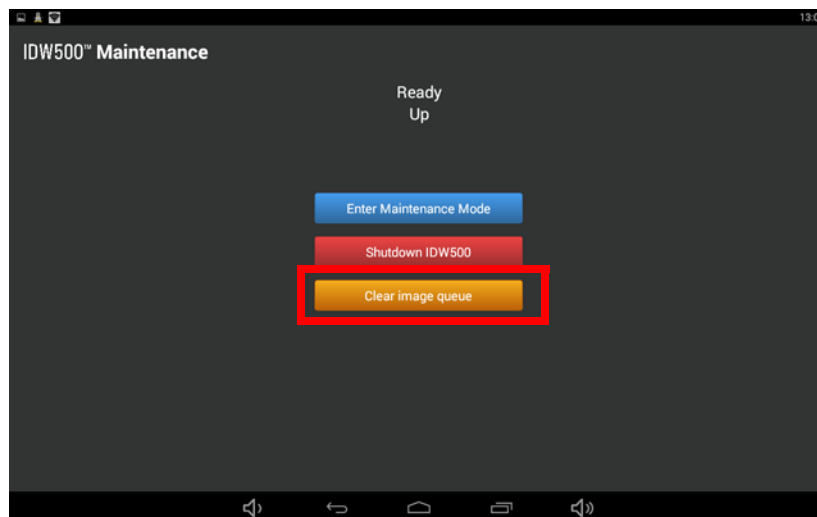

3. Any images that were on your console have now been deleted.
4. Press the **return icon** (second icon from the left) at the bottom of the screen to return to the main IDW500 home screen.

Saving Images to a USB Drive

Once you have sent an image to the IDW500 console, you have the option of saving the image to a USB drive.

1. Insert a USB drive into the console USB-4 port. It is recommended to plug the USB drive into the USB-4 port (see diagram below).

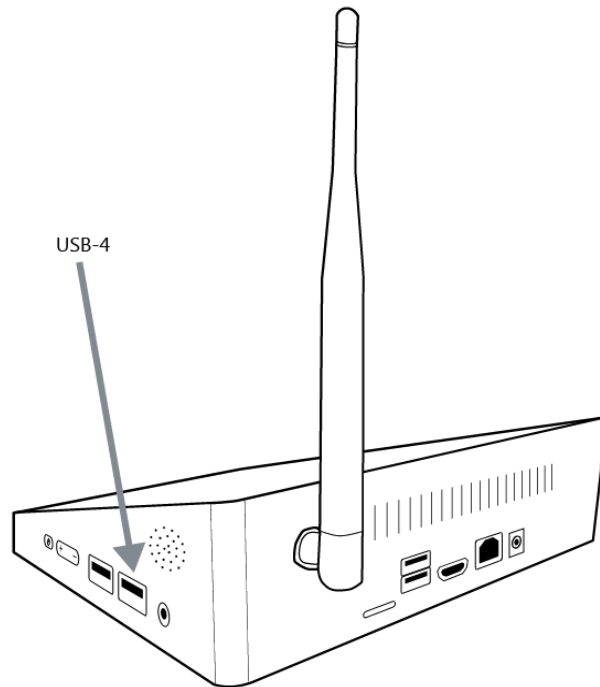

2. Take and send your image to your console.
3. If auto-print is enabled on your system, open the image you want to save from the image gallery.
4. From the Biometrics screen, press the **Accept** button (if no edits are needed.)

5. At the next screen, press the **Copy to USB** button.

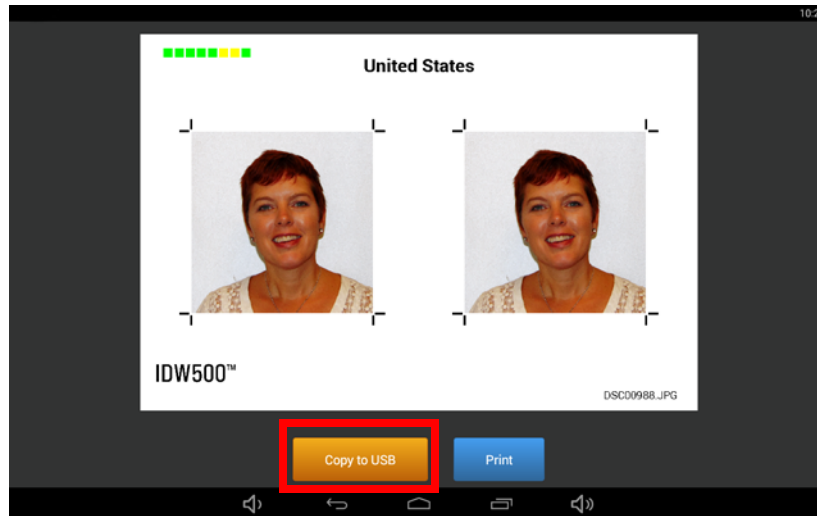

Note

If you have not inserted a USB device already, your console gives you a **Long Beep** noise as well as an **Insert USB Media** message. Do not remove the USB drive until you are instructed to do so later in this procedure.

6. When the image begins to transfer, your console gives you a **Pump** noise to let you know the image is being saved. Two images are saved to the USB drive, the original image that was taken on the camera, and the edited image.
7. As the image has finished transferring to the USB drive, your console gives you an **Alarm Clock** noise, as well as a **Remove USB Media** message.

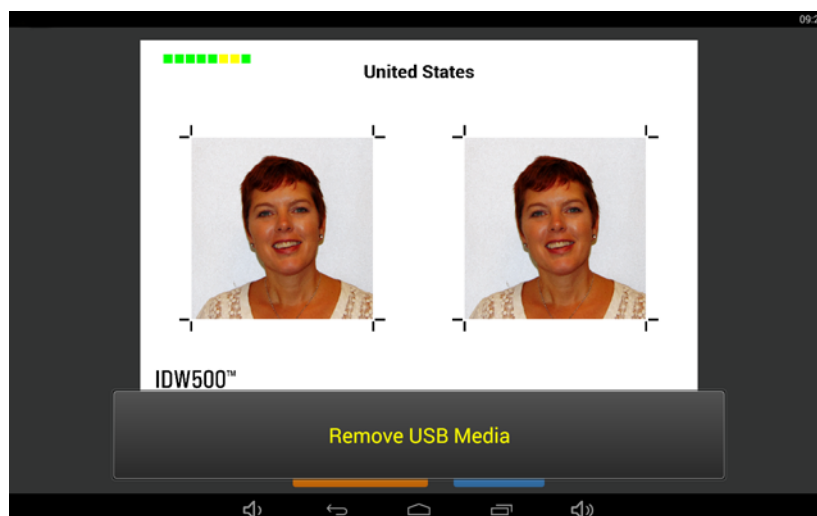

Printer Queue

You can check the status of the images you have sent to your printer. The **Print Queues** screen displays the images you have sent to your printer via the IDW500 console; this screen logs whether a sent image:

- ◆ Failed (did not print)
- ◆ Pending (waiting to be printed)
- ◆ Completed (printed)

1. From your console's main screen, press the **Printer** button.

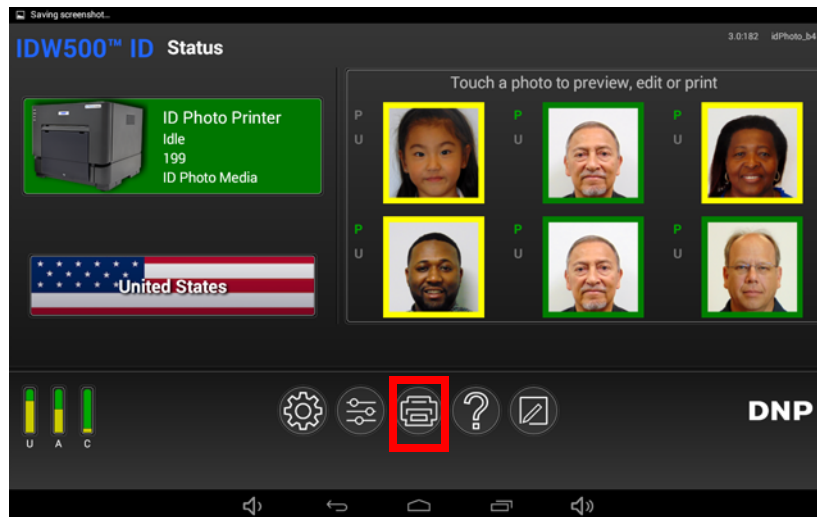

2. The **Printer Queues** screen is displayed. From this screen, you can view the various states of your image by pressing one of the following tabs: **Failed**; **Pending**; **Completed**.

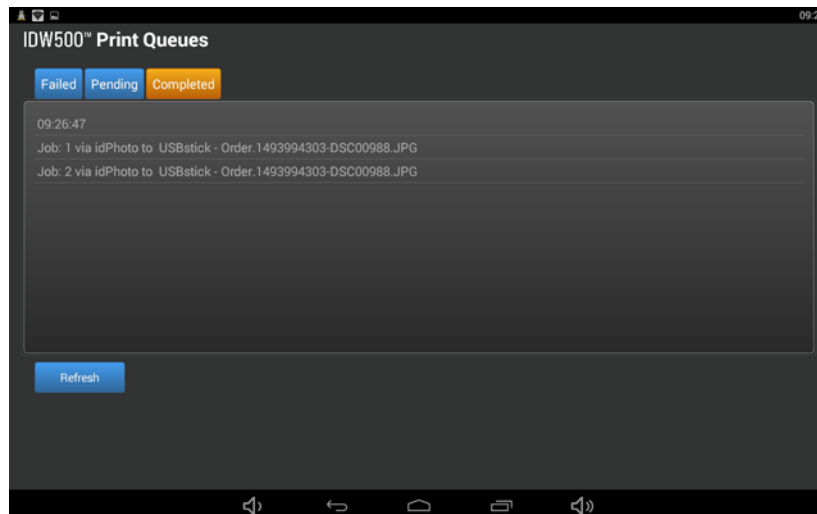

3. Return to the IDW500 main screen by pressing the **return icon** (second from left) on the bottom of the screen.

Shutting Down the IDW500 System



Note

It is recommended that you shut down your IDW500 System, daily, at the end of business.

1. To shut down the IDW500 console, press the **GEAR** icon on the main ID Photo screen.

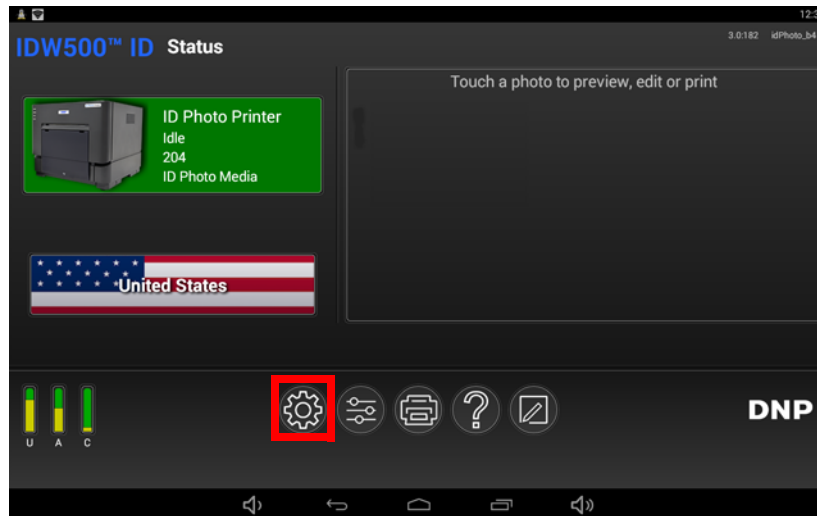

2. Press the **SHUTDOWN** button.

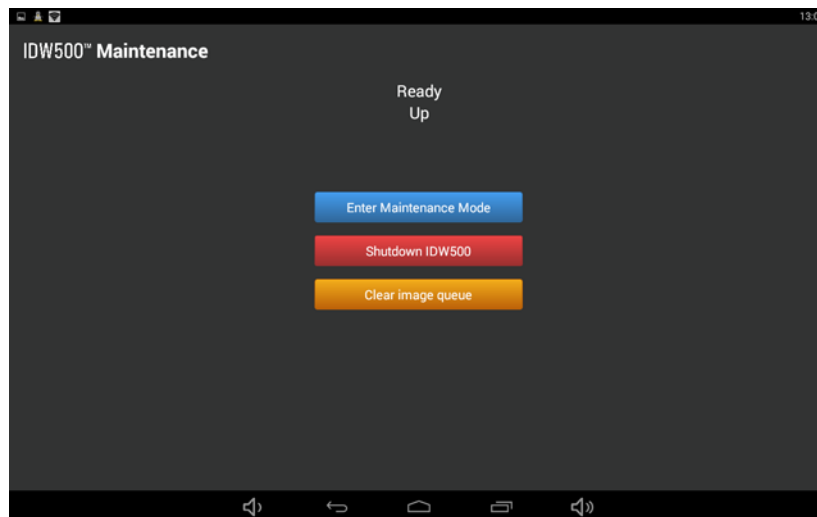

3. Once the console is powered OFF, turn off your printer and camera as well.

About the IDW500 Configuration Screen

Your IDW500 console arrives pre-configured to the settings you will need for daily operation. However, if you need to change any of the configuration settings, use this section to do so.



Attention

DNP Imagingcomm America Corporation recommends not changing the system from the default settings unless you have spoken with technical support. Doing so can cause inconsistencies and vary the output from the recommended tolerance thresholds.

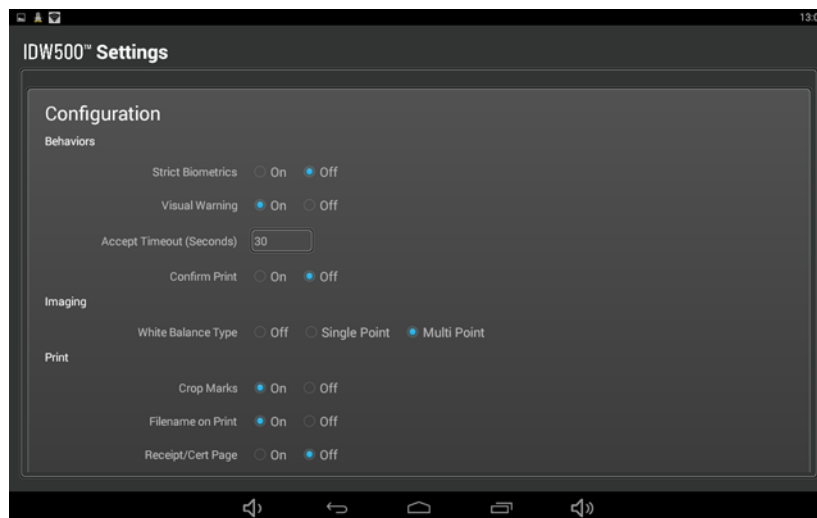

Accessing the IDW500 Configuration Screen

- To access the **IDW500 Configuration** screen, press the **Configuration** button on the bottom of your IDW500 console.

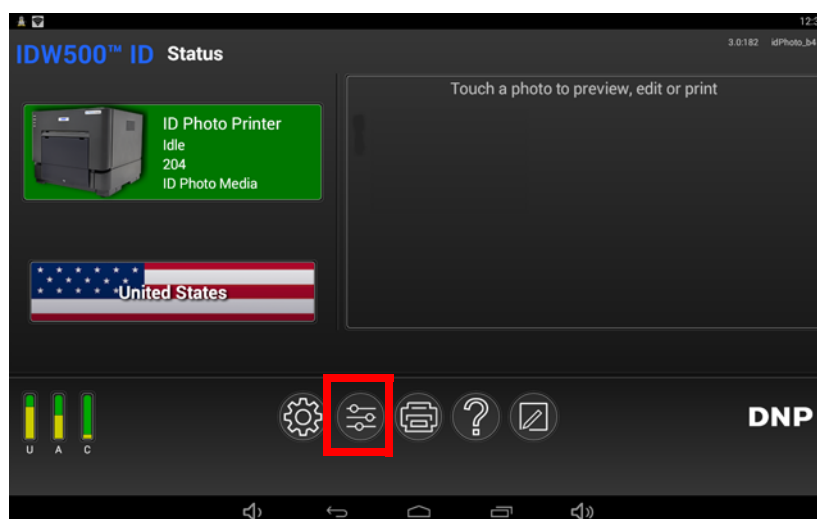

2. The **IDW500 Configuration** screen is displayed. The **IDW500 Configuration** screen is broken up into the following sections: **Behaviors**, **Imaging**, **Print**, **ID Types**, and **System**.

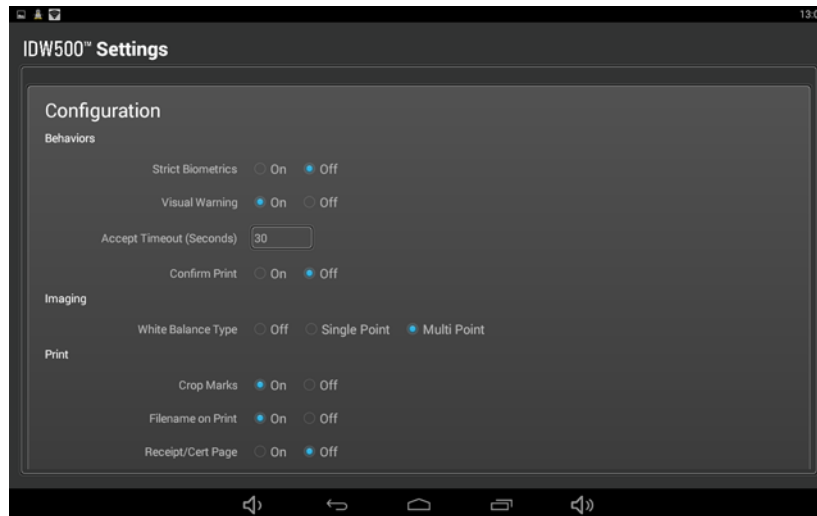

Behaviors Section

Under the **Behaviors** section of this page, you can configure the following items:

- ◆ **Strict Biometrics:** By turning this option **OFF**, you allow images that did not pass the biometric tests (Yellow state) to be printed automatically. This option is set to **ON** by default.
- ◆ **Visual Warning:** If this option is set to **ON** (by default), the background of the ID Photo acceptance screen displays Green, Yellow or Red depending on whether the image passed all the Biometrics requirements. Setting this option to **OFF** removes the warning colors (Green, Yellow, or Red) from the ID Photo acceptance screen.
- ◆ **Accept Timeout (Seconds):** When an image does not pass the Biometrics requirements, the ID Photo acceptance screen appears for the amount of time specified in this field. Please note that this feature only works when the **Visual Warning** option is set to **YES**.
- ◆ **Confirm Print:** Prompts the user to accept the image and send it to the printer. If this option is turned off, if the image passes all Biometric requirements, it is sent directly to the printer without the user being prompted. The default setting for this feature is **OFF**.
- ◆ **Auto-Print:** If you are using the auto-print feature, use the following settings to get the expected results.
 - Strict Biometrics **OFF**, Confirm Print **OFF** - both green and yellow images are auto-printed.
 - Strict Biometrics **ON**, Confirm Print **OFF** - only green images are auto-printed.
 - Confirm Print **ON** - auto-print is disabled, and prints can only be released by the operator.

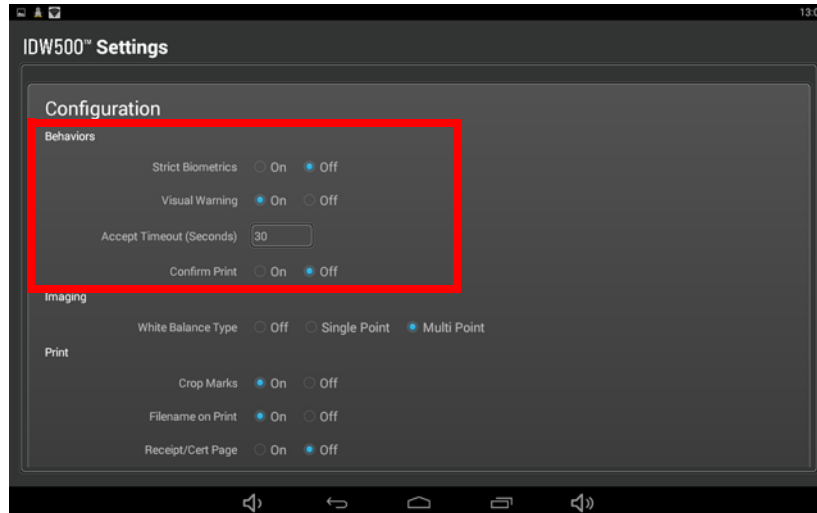

Imaging Section

Under the **Imaging** section of this page, you can configure the following item:

- ◆ **White Balance Type:** Control White Balance Definitions by using one of these settings.
 - Off:** Disables White Balancing.
 - Single Point:** The system uses one pixel from the upper left section of the image background to determine whether to lighten or darken the rest of the background.
 - Multi Point:** The system uses a group of pixels from the entire background of the image to determine whether to lighten or darken the rest of the background. This is the system's default setting.

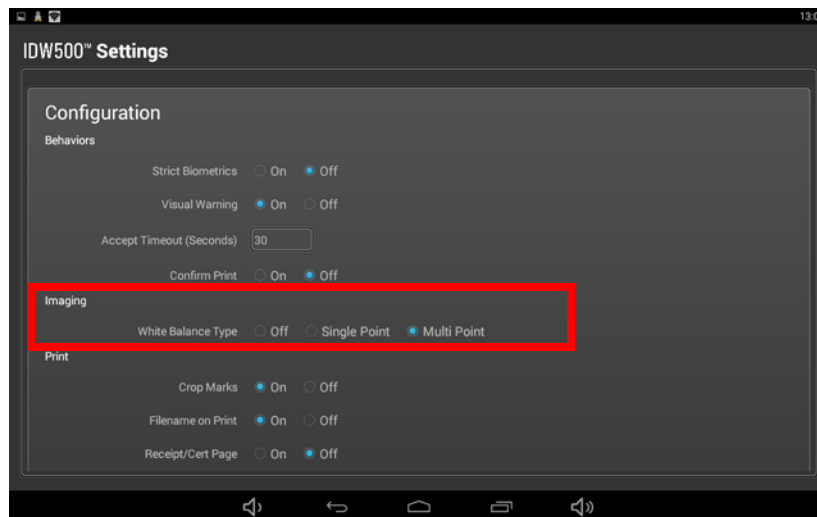

Print Section

Under the **Print** section of this page, you can configure the following items:

- ◆ **Crop Marks:** Enables/disables crop marks on the final print. Crop marks are helpful when cutting out the images. Default is ON.
- ◆ **Filename on Print:** Enables/disables displaying the file name on the final print. Default is ON.

- ◆ **Receipt/ITOC Certification Page:** Enables/disables printing a receipt.

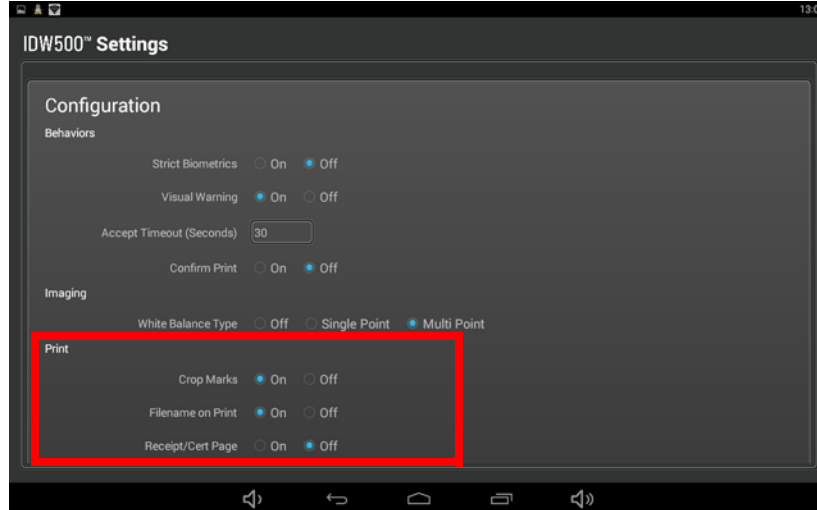

ID Types Section

Under the **ID Types** section of this page, you can configure the following items:

- ◆ **State:** Enabling/disabling state specific IDs. By default, this feature is set to **OFF**.
- ◆ **Local:** Enabling/disabling local IDs, e.g., university IDs. By default, this feature is set to **OFF**.

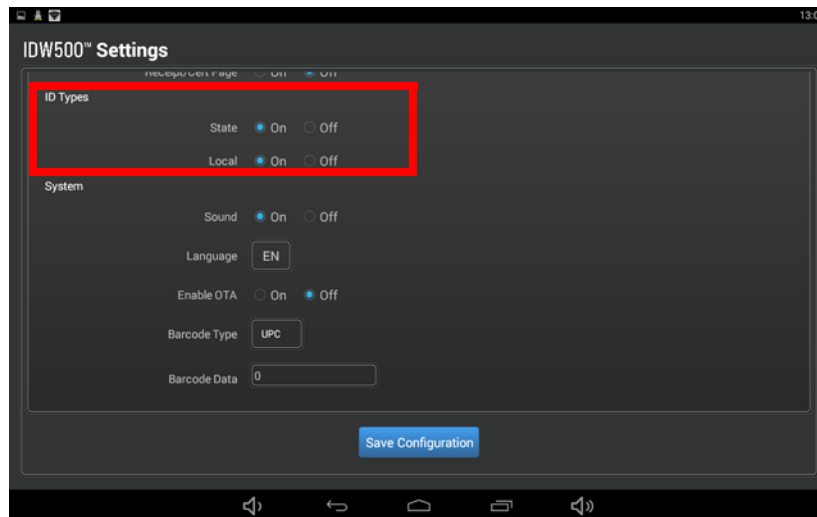

System Section

Under the **System** section of this page, you can configure the following items:

- ◆ **Sound:** Enables/disables sound. Default is **ON**.
- ◆ **Language:** Select the language to be displayed on your console.
- ◆ **Enable OTA:** Enables/disables OTA (over-the-air transmission).
- ◆ **Barcode Type:** Set the type of barcode, e.g. UPC, you want to include on printed receipts.

- ◆ **Barcode Data:** The data that will be associated with your barcode, e.g., UPC number.

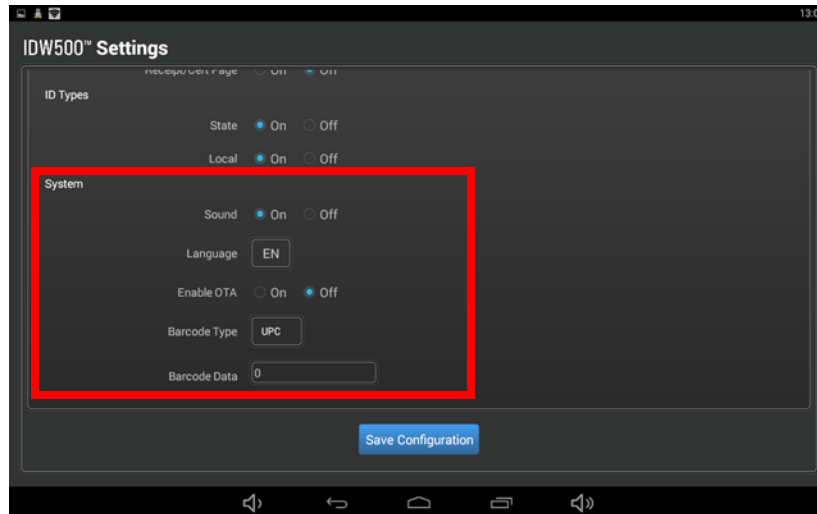

Erasing Images from the Camera

Use the camera menu to delete images. Do not reformat the SD card to erase images.

1. On the camera, press the **MENU** button.
2. Scroll DOWN ▼ to the **TOOL BOX** icon and press **SELECT**.
3. Scroll DOWN ▼ to **MEMORY CARD TOOL** and press the **RIGHT ARROW** ►.
4. Scroll DOWN ▼ to **DELETE REC. FOLDER**, and press **SELECT**.
5. Scroll DOWN ▼ to **OK**, press **SELECT**.
6. Press **MENU EXIT** or the **POWER** button to return to shooting mode.

Erasing all Images on the Camera

1. On the camera, be sure that you are in **playback mode** (play button).
2. Press the **Delete** button (trashcan button).
3. Select the **Delete All Images on this Date** option and press the Enter button.

Enabling the Flash

Use the camera flash if needed to increase the quality of your photos.

1. Depending on the camera, press the **FLASH** button to enable the flash.
2. Press the **RELEASE** button on the side of the flash housing to raise the flash hood.



Note

For difficult lighting conditions force the flash to ON.

3. Select the **P MODE** on the mode select dial.
4. Press the **FLASH SYMBOL**  or **REAR PANEL** control and select the **FLASH SYMBOL** (not Auto nor SL flash).

Printing Directly from the Camera via USB Cable

You can also print images by plugging the camera directly to your IDW500 console via USB cable.

1. Plug the camera into the USB-4 port on the side of the camera.
2. Once plugged in via, USB, the last six images that were shown on the console are printed.
3. Once the images are printed, they are removed from the camera SD card. This is to keep the images from being reprinted every time the camera is plugged into the IDW500 console.



Attention

Please be advised that using this printing method, the printed images are permanently deleted off of the camera's SD card once they are printed.

Using the IDW500 Printer

About your Printer

Your ID Photo Printer printer comes with a user manual as well as other documentation should you need in-depth instructions on operating your printer. For daily use, the procedures in this chapter provide basic usage instructions as well as some troubleshooting and maintenance steps.



Attention

Be sure to save your shipping box! If you need to transport your printer or send your printer in for repairs, the original shipping box is the safest packing option. Just put the packaging materials (including the print head protection foam block) back in the box and store it in a safe place.

Replacing the Printer Media

Always replace both the ribbon and paper at the same time.

1. Remove the print catch tray from the front of the printer and empty the paper scrap box.



2. Press the release lever on the top of the printer to open the media door.



3. Throw away the old ribbon.
4. Remove the paper spool. Take the spool ends off of the spent paper roll and throw away the roll. (Do not throw away the spool ends.)
5. Load your new paper roll onto the spool ends. Make sure that there are no gaps and that the paper roll is not bulging to one side.

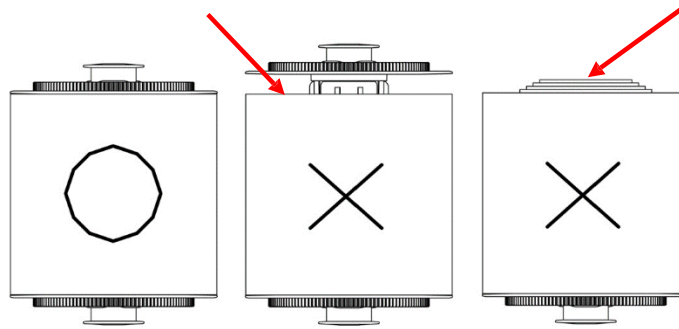

6. Place the paper spool into the printer so that the leading edge of the paper feeds over the top of the roll.
7. Remove the PULL tab.

8. Feed the paper roll leading edge into the feed path. Align the paper edges with the PC lines on the printer. Feed the paper under the black guide roller. Continue to feed the paper until the printer beeps. This means that the paper is in the correct position.

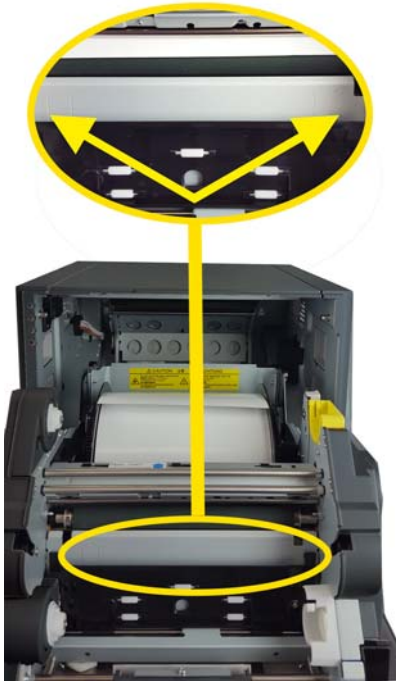

9. Set the ribbon supply side (two white ends) in the lower, or front, brackets. Set the take-up side (one white and one yellow end) in the upper, or back, brackets. Insert the left side of the ribbon spool into place first, then snap the right side of the spool into place. Wind the take-up spool to remove any slack in the ribbon. The supply spool feeds over the top while the take-up spool feed underneath.



10. Close the printer media door. Five blank prints are ejected.
11. Replace the scrap box and the print catch tray.

Maintaining the Printer

Cleaning the Platen Roller



Attention

Only use the pre-saturated wipes from this kit. Avoid sharp edges when cleaning the printer. You should only clean the platen roller if you are instructed to do so by technical support.

1. Clean the platen roller if you experience soft, blurry lines on your prints that run in the same direction of the print feed.
2. Release the open lever and open the front cover.



3. Remove the ribbon tray and set it aside.
4. Remove the paper spools and set them aside.
5. Using the provided pre-saturated wipe, wipe the platen roller while rotating the roller slightly. Use a clean portion of the wipe for each swipe.



6. Wait at least 3 minutes for the roller to dry, then replace the paper and ribbon.
7. Close the printer securely and wait for the printer to initialize.

Cleaning the Thermal Print Head



Attention

You must wait a minimum of 5 minutes before cleaning the thermal head to avoid severe burn injuries. Never use water to clean the thermal head. You should only clean the print head if you are instructed to do so by technical support.

Clean the thermal head if print quality has decreased and/ or you see hard lines in the middle of prints. Always clean the platen roller first.

1. Release the open lever and open the front cover.



2. Remove the ribbon tray and set it aside.
3. Remove the paper spools and set them aside.
4. Locate the thermal head in the printer chassis. Look for the line where the orange and black strips meet on the head.

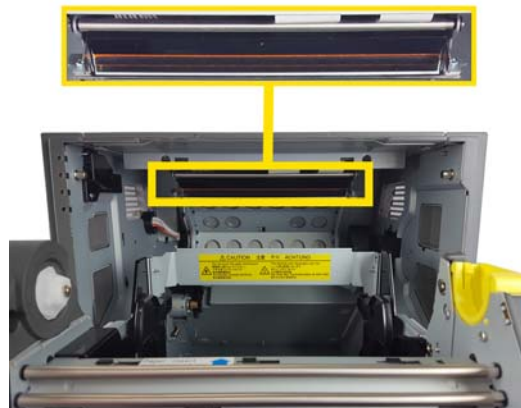

5. Using the cleaning pen, swipe the thermal head in a side to side motion. Clean the entire length of the thermal head.
6. If you see dirt or debris on the thermal head, use the thermal head wipe to clean only the dirty portion of the thermal head.
7. Wait at least 3 minutes for the head to dry, then replace the paper and ribbon.
8. Close the printer securely and wait for the printer to initialize.

Repacking the Printer

To transport the printer, repackage the printer with the original packaging material. Failure to do so will void any warranty. If the original packaging materials are not used or the printer is not packed correctly, the printer may be broken during transport. Always save the print head protective foam. Do not throw away any packaging as it is needed to safely transport the printer.

Remove all accessories, media, and attachments from the printer – this includes all the ribbon, paper roll, and paper spools as well as the USB and power cables. Place the accessories in the accessory box.

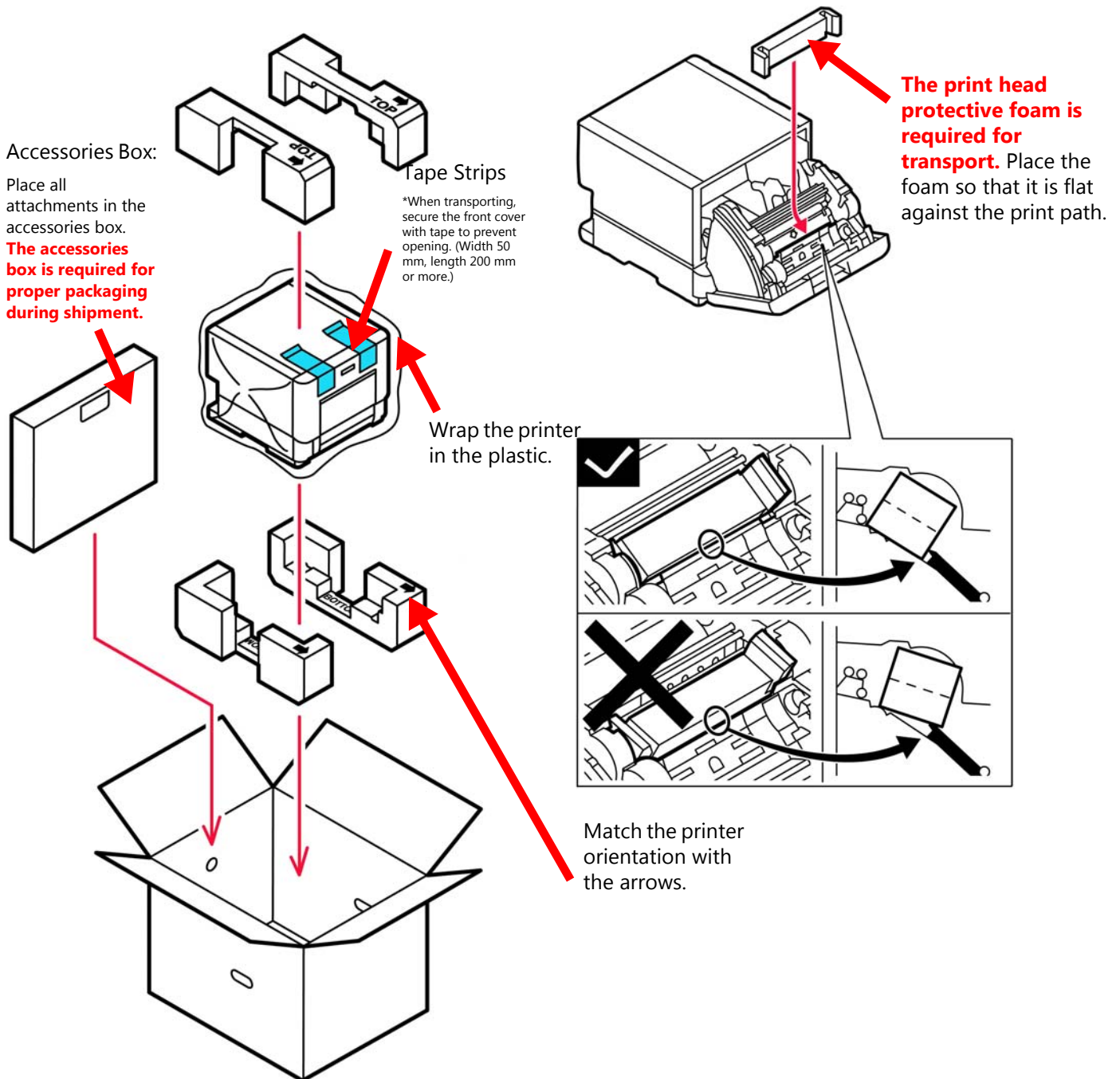

Troubleshooting Printer Issues

Clearing Paper Jams

1. Open the printer media compartment using the release lever on the front of the printer.
2. Remove the ribbon.
3. Carefully pull any remaining paper from the paper path.

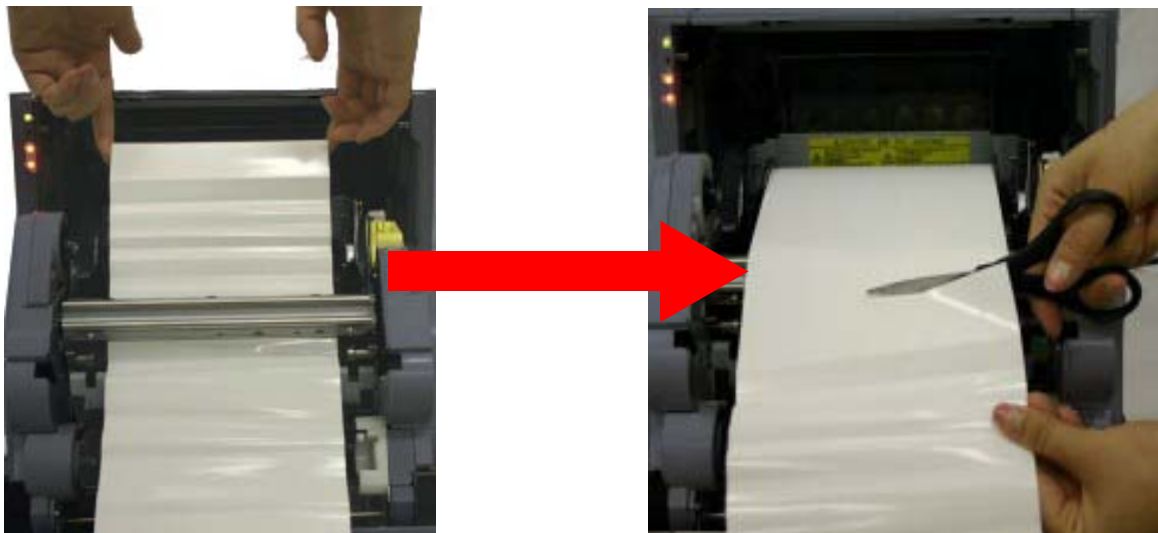
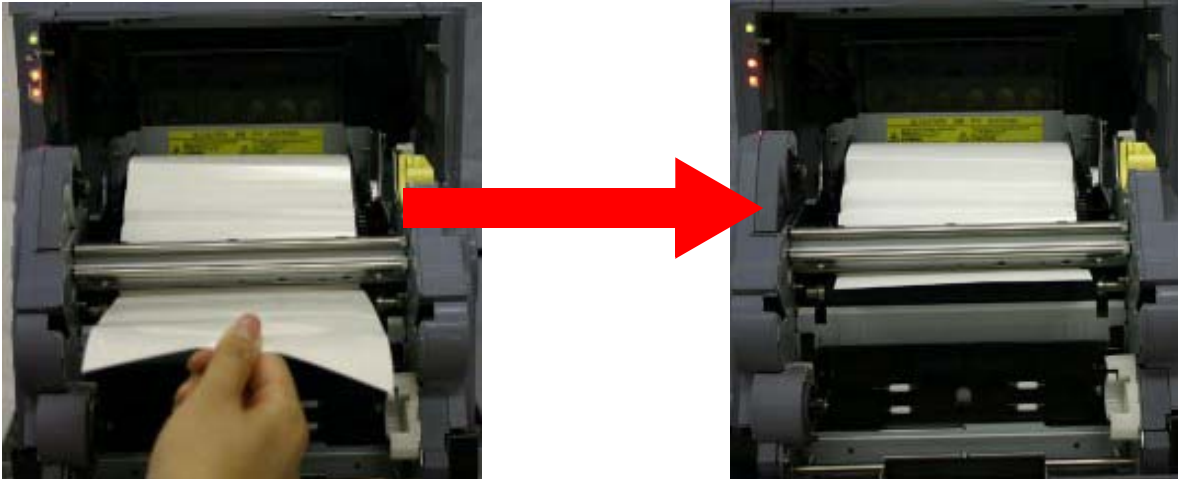

4. Cut the paper and remove the paper roll from the printer.

5. Cut the paper roll to remove any wrinkled or bent paper from the roll. Printing over bent paper can damage the printer and cause more paper jams.

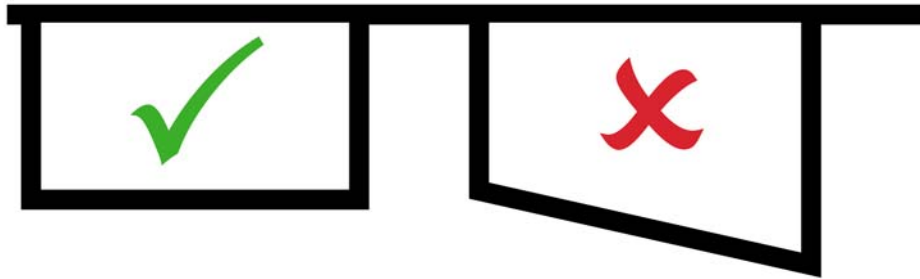

6. If the paper is not cut evenly, it may cause abnormal printing and or the paper to jam. Re-feed the paper as you would when loading a new paper roll.

Clearing Ribbon Jams

1. Remove any ribbon remaining in the printer.



2. Remove any incomplete or jagged ribbon panels.

3. Use clear tape to reattach the two ribbon spools.



4. Replace the ribbon in the printer and wind the ribbon a few times to remove any slack and until the tape is no longer seen.



5. Close the media compartment.

Troubleshooting the System

General Troubleshooting Steps

If you experience any issues with your system use the steps below to troubleshoot the issue.

1. Did the IDW500 print a test page when you powered ON the system?
 - ◆ **YES:** Continue with step 3.
 - ◆ **NO:** Check the printer status icon. Touch the bottom right portion of the main dashboard. If the printer state is idle, continue with step 3. If the printer state is anything besides idle, check the printer for error conditions and check that the media is properly loaded. Continue with step 2.
2. Power cycle the IDW500 console.
 - ◆ To do this, press the **POWER** button on the unit. A test print should print.
3. Check the IDW500 printer status icon. If the printer is shown to be in a ready state, continue below. If the printer isn't in a ready state, power cycle the printer and the console, and then continue.
4. Verify that the camera has at least half battery power available.
 - ◆ If the camera has less than half of the battery power remaining, change or recharge the camera batteries.
5. Make sure you are standing within 15 feet of the IDW500 console.
 - ◆ If you are in an environment with a large amount of wireless traffic, try standing closer to the unit.
6. Listen for the ping that tells you the camera is connected to the IDW500 console. Check for the **CAMERA FOUND** message on the console screen.
7. If you cannot hear the ping, but can see the message on the screen, check your system volume levels. If there is no ping and no message, power cycle the camera and wait to see if the system discovers it.
8. If you are still experiencing issues with your system, contact technical support at 1.844.367.8777.

Reconfiguring the SD Card

To reconfigure the SD card, use the IDW500 SD Recovery utility.

You can find the latest copy of the IDW500 SD Recovery utility on the DNP Imagingcomm America Corporation website. Check the Downloads section, and locate the utility you want to use.

Once you have installed the utility on your system, you can use the utility to repair an SD card or set the ID number for the SD card. For more information about how to use the SD Recovery utility, contact technical support.

Repairing the SD Card

1. Press the **Repair** button.

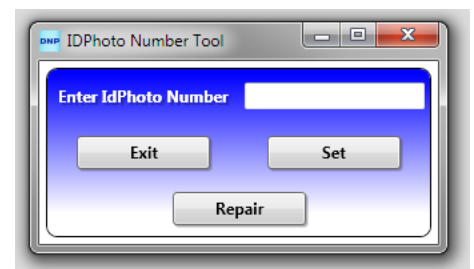

2. Select the drive location to restore the card from.

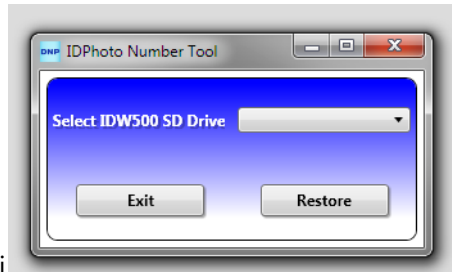

3. Press the **Restore** button.

Setting the ID Number



1. Locate the idPhoto number for the system. the idPhoto number is the set of characters after the idPhoto_ tag in the SSID field. You can locate the number on the upper right corner of the home screen on the console, or on the POST print by finding the SSID number field.



Figure 2. The idPhoto number in this example is b4.

2. Enter the **IDPhoto number** in the field on the screen.
3. Press the **Set** button.